



PO BOX 4394
SANTA ROSA, CA
95402 USA

P (707) 525-9941
F (707) 575-7046
EMGPICKUPS.COM

X-SERIES

INSTALLATION INFORMATION

EMG MODELS: **EMG-S-X, SA-X, SAV-X, SLV-X**

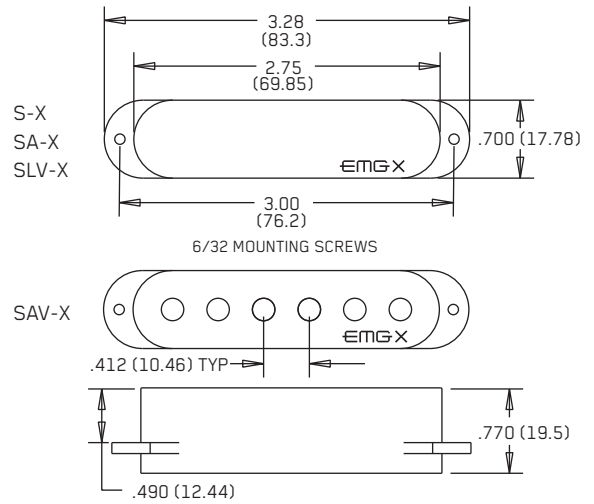

SPECIFICATIONS:

	MODEL:				
	S-X	SA-X	SAV-X	SLV-X	
Logo Color	Silver	Gold	Gold	Gold	
Magnet Type *	C	A	A	A	
Resonant Frequency (KHz)	4.52	4.05	4.55	3.50	
Output Voltage (String)	1.00	1.00	1.00	1.00	
Output Voltage (Strum)	3.00	3.00	3.00	3.00	
Output Noise (60 Hz)	-107	-107	-101	-103	
Output Impedance (Kohm)	2.00	2.00	10	10	
Current @9V (Microamps)	80	80	80	80	
Battery Life (Hours)	3000	3000	3000	3000	
Maximum Supply (Volts DC)	27	27	27	27	

*Note: Magnet Type: A (Alnico) C (Ceramic)

INSTALLATION NOTES:

All EMG Pickups are compatible with each other. The connector system is an easy method of installation, avoiding the need to solder. Older systems may need to be soldered, while the newer systems can be easily connected and modified. If you have an older EMG Pickup you can install the new system along with it.

EMG accessories like the EXG, SPC or RPC Controls can be added to any EMG Pickup System without the need for an extra battery.

INCLUDED WITH EACH PICKUP:

- 1 VOLUME CONTROL (25K)
- 1 ACTIVE TONE CONTROL

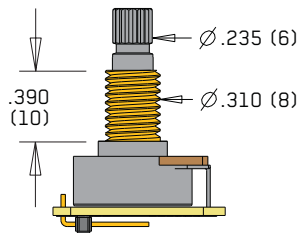

ADJUSTMENT
SCREWS & SPRINGS



2 PICKUP IN/ OUT
BATTERY BUSS

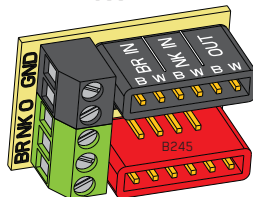

BATTERY
BUSS

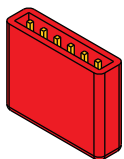

STEREO OUTPUT
JACK

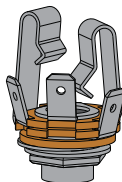

PICKUP CABLE 15" (38cm)

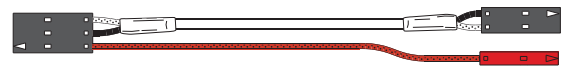

2 CONNECT CABLES 5.5" (14cm)

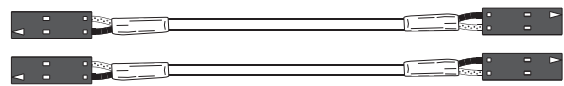

OUTPUT CABLE 6" (15cm)

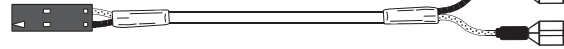

SUPPLY CABLE 5.5" (14cm)



BATTERY CABLE 7" (18cm)



WARRANTY

All EMG Pickups and accessories are warranted for a period of two years. This warranty does not cover failure due to improper installation, abuse or damage. If upon examination the pickup is determined to be defective, a replacement will be made. Warranty replacement products are covered by this same warranty. This warranty covers only those pickups and accessories sold by authorized EMG Dealers. This warranty is not transferable.

Installation Instructions:

EMG Models: EMG-S-X, SA-X, SAV-X, SLV-X

General Notes:

Every attempt has been made to make this a solderless installation. There are some instances where this is not possible;

- 1) If your instrument uses the long panel output jack and you had passive pickups you will need a new stereo output jack, the Switchcraft 152B is recommended. Soldering to the new jack will be required, see page 4.
- 2) Power Supply tips are on page 4. If your instrument has a battery holder, you are installing this pickup with an older EMG, or you want to supply your instrument with +18 Volts, see page 4 for tips to avoid soldering.

If you are installing only one pickup use the instructions on this page. If you are installing two pickups go to page 3 and begin there.

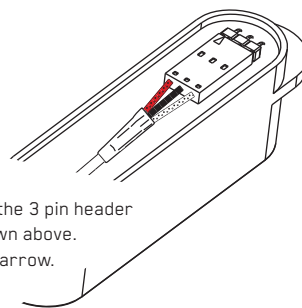

Diagram #1
Insert the plug onto the 3 pin header of the pickup as shown above. Note the orientation arrow.

Installation (One Pickup Guitars):

- 1) Plug the pickup cable onto the EMG Pickup header as shown in Diagram #1 and route the cable to the control cavity. If the cable is too long, wind up the excess and keep it under the pickup if possible.

Master Volume control only

- 2) Refer to Diagram #2. Plug both the Pickup cable and the output cable onto the Volume control as shown, then go to step 4.

Master Volume and Active Tone control

- 3) Refer to Diagram #3. Install the VLPF Active Tone included with the X Series Pickup. Plug a coax cable from the Volume control to the Active Tone Control. (Note the reversed connector on pins 1 and 2). Insert the output cable onto the Tone control as shown (Pins 3 and 4).
- 4) Connect the output wires to the output jack by pushing the connectors onto the jack as shown. WHITE wire to the TIP (T) contact, BLACK wire to the SLEEVE (S) contact, BLACK Battery Negative wire to the RING (R) contact.
- 5) Using the battery buss, insert the RED wire of the pickup, the battery RED wire, and the RED wire from the VLPF onto any of the pins. Extra pins can be used for EMG Accessories.
- 6) Put the battery in the insulating foam piece provided and place it securely in the control cavity. We suggest that you plug in the instrument and test it before closing the control cavity.

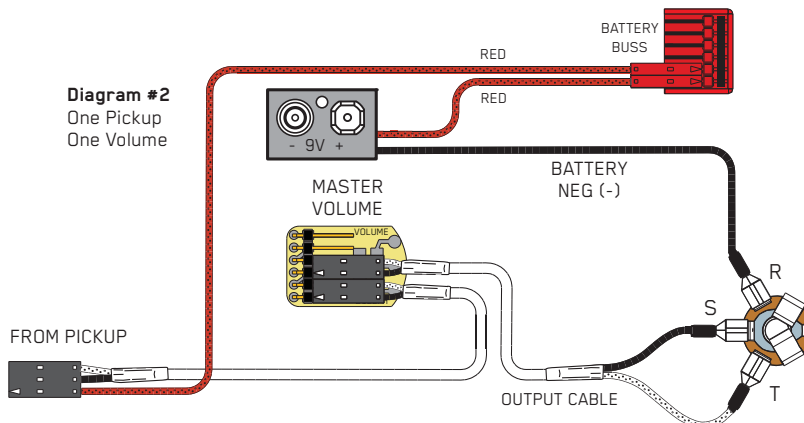

Diagram #2
One Pickup
One Volume

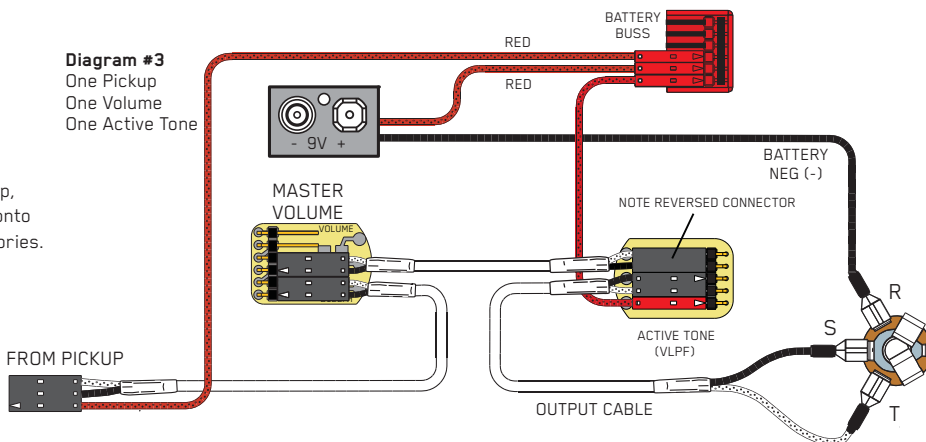

Diagram #3
One Pickup
One Volume
One Active Tone

Diagram #4

Soldering to the 152B Panel Jack:

If your instrument has a long Panel Jack like the one below you will have to solder the output cable as shown. Ground (Black) to the sleeve, Signal (White) to the Tip, Battery Negative (Black) to the Ring.

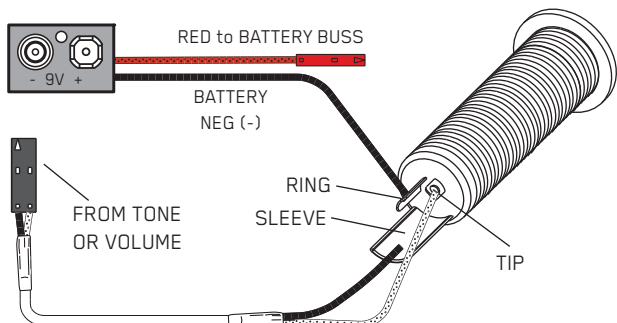
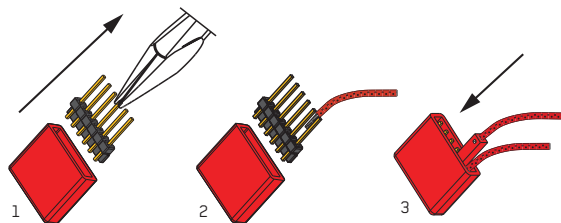

Diagram #5

Soldering to the battery buss:

If your instrument has an older EMG Pickup you can solder the pickup RED wire to the buss. Simply use some needle nose pliers, pull out the V+ header and solder the RED Wire from the pickup(s) to any of the pins and then re-insert the header into the housing.



Solder the RED wire from the Battery Holder and/or pickups and re-insert the Header into the insulation cover

Installation Instructions:

EMG Models: EMG-S-X, SA-X, SAV-X, SLV-X

Installation (Two Pickup Guitars with Selection switch):

Guitars with two pickups and a selection switch will use the EMG B245 Pickup Buss. The Pickup Buss is a convenient way to wire your guitar without soldering. There is a separate sheet attached to these instructions that describes the Pickup Buss in detail.

In all installations it's best to find a place to mount the Pickup Buss in the control cavity before starting. Then, after the cables are routed use the velcro to mount it securely.

2 Pickups / Toggle Select Switch / Master Volume and Tone

- 1) Install the Pickups and route the Pickup cables to the control cavity.
If the cables are too long, wind up the excess and keep it under the pickup.
- 2) Mount the Volume and Tone controls into the body.
Plug both Pickup cables into the Pickup Buss (BLACK Shroud) as shown,
Refer to Diagram #6a
Bridge Pickup to Position 1
Neck Pickup to Position 2.
- 3) Plug a coax cable from the Pickup Buss (Position 3) to the Master Tone (Active) as shown in Diagram #6b. Note the reversed connector on pins 1 and 2.
- 4) Plug a coax cable from the Master Tone (ACTIVE) to the Master Volume as shown.
- 5) Strip the insulation from the switch wires and Insert them into the GREEN Terminal Block and tighten the screws with a small screwdriver.
The Bridge pickup goes to the BR Terminal
The Neck pickup goes to the NK Terminal
The Output of the switch goes to the O Terminal
If there is a ground wire coming from the switch, insert it into one of the black terminals on the terminal block.
- 6) Plug the output cable onto the Master Volume control and connect the output wires to the output jack and push the connectors onto the jack as shown.
WHITE wire onto the TIP (T) contact,
BLACK wire onto the SLEEVE (S) contact
BLACK Battery Negative wire onto the RING (R) contact.

- ****Tips and Tricks**** Start your installation by:**
- 1) Determine which type output jack your instrument has.
A Stereo 12B type is Included, but if you have a long panel jack a SwitchCraft 152B Long Panel Jack will be required.
 - 2) Remove the strings, remove any existing Pickups and controls (remember the order and function of each control)
 - 3) Determine a good spot for the Pickup Buss and make sure the cable or wires from the selection switch will reach the Pickup Buss,
 - 4) Install the EMG Volume and Tone Controls and tighten them in.
 - 5) Then install the pickups keeping any excess cable under the pickup rather than in the control cavity.
 - 6) **IMPORTANT: EMG Active pickups do not require a string ground wire! DO NOT Reconnect the string ground, it is unnecessary.**
- 7) Plug the RED Wires of the pickups onto the V+ Supply Buss (RED Shroud) along with the RED of the battery clip, and the RED wire of the Active Tone Control. Extra pins on the V+ Supply Buss are for EMG Accessories.
 - 8) Put the battery in the insulating foam piece provided and place it securely in the control cavity.
We suggest that you plug in the instrument and test it before closing the control cavity.

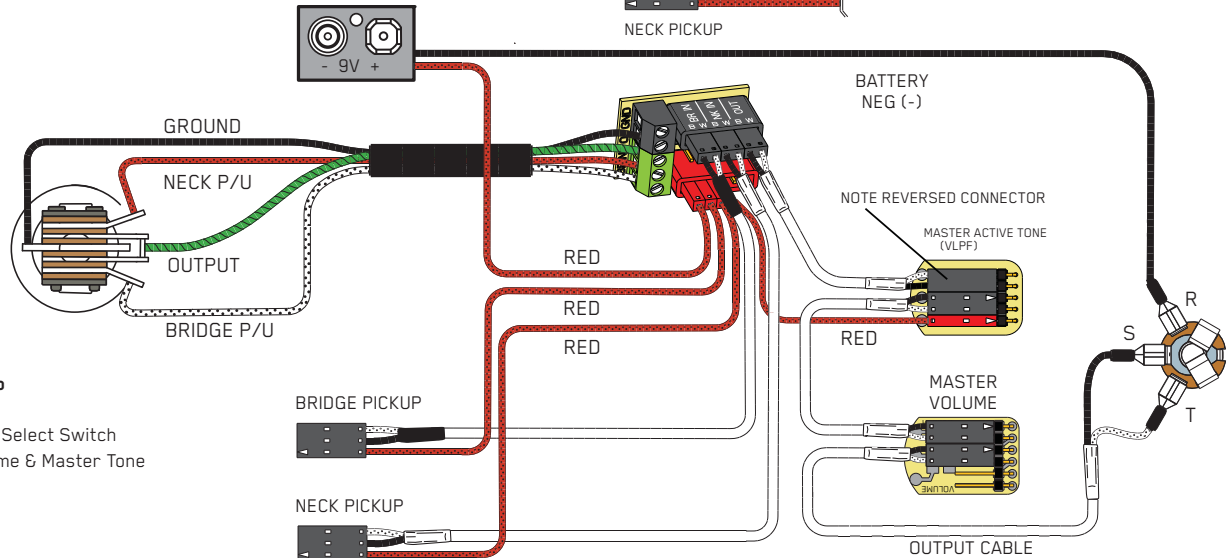
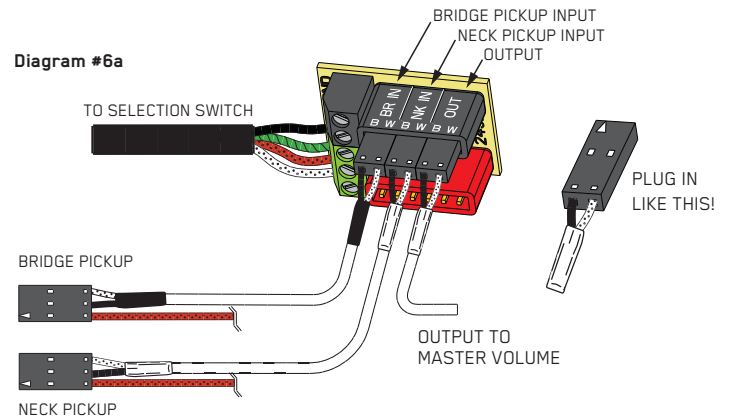
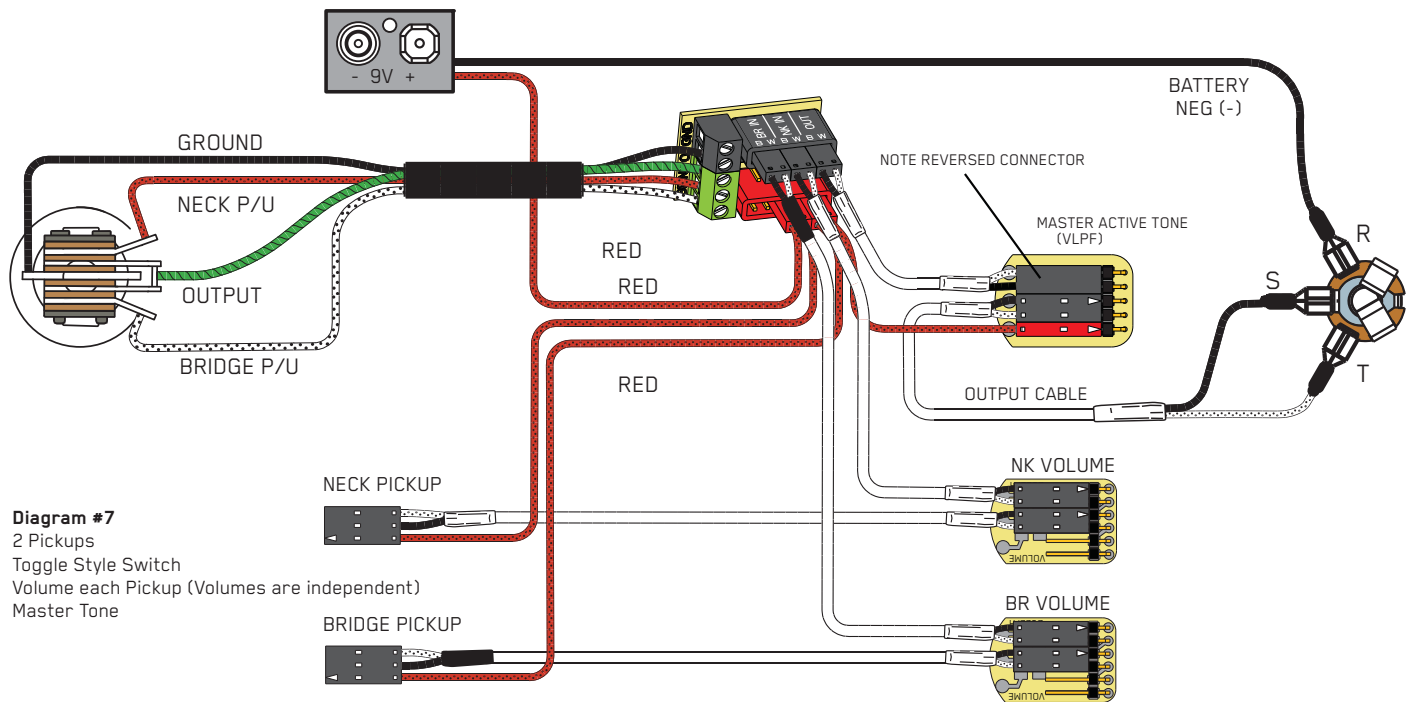

Diagram #6b
2 Pickups
Toggle Style Select Switch
Master Volume & Master Tone

2 Pickups / Toggle Select Switch / 2 Volumes and Master Tone

Refer to Diagram #7 (Next Page)

- 1) Install the Pickups into the instrument and route the cables to the control cavity.
If the cables are too long, wind up the excess and keep it under the pickup.
- 2) Mount the Volume and Tone controls into the body.
Plug both pickup cables onto the Volume controls as shown.
Plug a coax cable from the Bridge Volume control to the Pickup Buss (Position 1)
Plug a coax cable from the Neck Volume control to the Pickup Buss (Position 2)
- 3) Plug a coax cable from the Pickup Buss (Position 3) to the Master Tone (Active) as shown. Note the reversed connector on pins 1 and 2.
- 4) Strip the insulation from the switch wires and Insert them into the GREEN Terminal Block and tighten the screws with a small screwdriver.
The Bridge pickup goes to the BR Terminal
The Neck Pickup goes to the NK Terminal
The Output of the switch goes to the O Terminal
If there is a ground wire coming from the switch, insert it into one of the black terminals on the terminal block.
- 5) Plug the output cable onto the Active Tone control (Pins 3 and 4) and connect the output wires to the output jack and push the connectors on as shown.
WHITE wire to the TIP (T) contact,
BLACK wire to the SLEEVE (S) contact
BLACK Battery Negative wire onto the RING (R) contact.
- 6) Plug the RED Wires of the pickups onto the V+ Supply Buss (RED Shroud) along with the RED of the battery clip. Extra pins are for EMG Accessories.
- 7) Put the battery in the insulating foam provided and place it securely in the control cavity.
We suggest that you plug in the instrument and test it before closing the control cavity.



2 Pickups / Toggle Select Switch / 2 Volumes and 2 Tones

Refer to Diagram #8

1) Install the Pickups and route the cables to the control cavity.

If the cables are too long, wind up the excess and keep it under the pickup.

2) Mount the Volume and Tone controls into the body.

Plug both Neck and Bridge pickup cables onto the Volume Controls as shown.

3) Plug a coax cable from the Bridge (BR) Volume control to the (BR) Active Tone Control. Note the reversed connector on pins 1 and 2.

4) Plug a coax cable from the Neck (NK) Volume control to the (NK) Active Tone Control. Note the reversed connector on pins 1 and 2.

5) Plug a coax cable from the (BR) Active Tone to Position 1 on the Pickup Buss.

6) Plug a coax cable from the (NK) Active Tone to Position 2 on the Pickup Buss.

7) Strip the insulation from the switch wires and Insert them into the GREEN

Terminal Block and tighten the screws with a small screwdriver.

The Bridge pickup goes to the BR Terminal

The Neck pickup goes to the NK Terminal

The Output of the switch goes to the O Terminal

If there is a ground wire coming from the switch, insert it into one of the black terminals on the terminal block.

8) Plug the output cable from the Pickup Buss (Position 3) to the output jack and push the connectors onto the jack as shown.

WHITE wire onto the TIP (T) contact,

BLACK wire onto the SLEEVE (S) contact

BLACK Battery Negative wire onto the RING (R) contact.

9) Plug the RED Wires of the pickups onto the V+ Supply Buss (RED Shroud) along with the RED of the battery clip, and the RED wires from the Active Tone Controls.

10) Put the battery in the insulating foam piece provided and place it securely in the control cavity.

We suggest that you plug in the instrument and test it before closing the control cavity.

Diagram #8

2 Pickups

2 Volume (either volume will act as a master)

2 Tone

Toggle Style Switch

