



0230-0204-E

PO BOX 4394
SANTA ROSA, CA
95402 USA

P (707) 525-9941
F (707) 575-7046
EMGPICKUPS.COM

**PASSIVE
PICKUP
INPUTS**

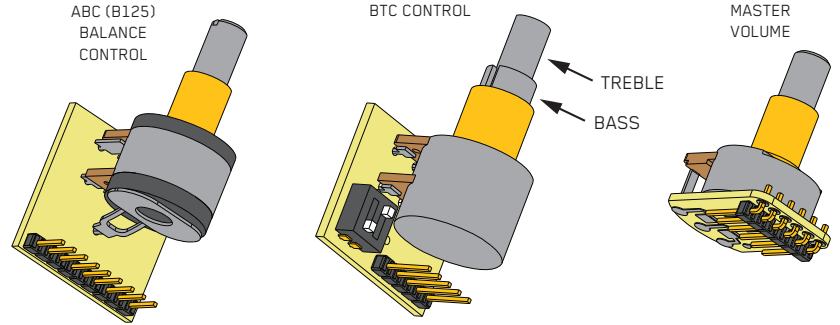

INSTALLATION INFORMATION EMG MODEL: **BTC-HZ SYSTEM** (PASSIVE PICKUP INPUT)

SPECIFICATIONS

Input Impedance (kΩ)	500
Typical Output Noise (dBV)	-120
Output Impedance (kΩ)	2.0
Current Draw @9V (mA)	2.15
Current Draw @18V (mA)	2.40
Maximum Supply (Volts DC)	27

INCLUDED:

- B125 ABC Control
- BTC Control
- Volume Control (25kΩ)
- Rubber Knobs
(2 Standard, 1 Concentric)

- Battery Clip with V+ Power Bus
- 2 Power Supply Cables, 5.5" (Red)
- 2 Connect Cables, 5.5" (Black/White)
- Output Cable, 6.4" (Black/White)
- Stereo Output Jack

ABOUT THE BTC-HZ SYSTEM:

The BTC-HZ System is a complete control system for bass guitars. Active Balance, Master Volume and EQ circuits are included. Additionally, the BTC-HZ System includes solderless wiring components intended for the most common installations.

The EQ circuit allows you separate control over the Bass and Treble frequencies. Rotate the controls clockwise to boost, and counterclockwise to cut. All EQ controls have a center detent (click) to indicate a flat / unaffected response.

One of four distinct Treble frequency response curves can be selected by DIP switches on the primary circuit board. All EQ effects are illustrated in the graphs on Page 2.

The B125 Active Balance Control (ABC) is used to pan between two pickups, rather than relying on a selection switch. The B125 features input buffers for each pickup, so it can be used to combine 2 Passive Pickups, 2 Active Pickups, or even 1 Active pickup with 1 Passive pickup. The control has a center detent in the middle of its rotation. If the combination of Active and Passive pickup signals results in a thin/weak out-of-phase sound, you may need to reverse the default wiring of your Passive pickup. For more details on using the B125 Active Balance Control, refer to its separate instructions which can be found on its product page at emgpickups.com.

The ABC and BTC Control both have low output impedance, so a 25kΩ Volume control is included to match this low-impedance system. Do not use any existing high-resistance (i.e. 250/500 kΩ) Volume and Tone with the BTC-HZ System. Doing so may result in excess noise.

INSTALLATION INFORMATION:

BATTERY POWER:

When using any type of EQ or boost in your instrument (EMG-BT, BQ, EXB, etc.), operation at +18 Volts is recommended for improved headroom. See Page 4 for guidance on +18 Volt wiring. To conserve battery life, always unplug your instrument when you're not using it.

WIRING ORDER:

Below is a diagram of the ideal wiring order of the controls. The lowest possible noise floor is achieved by placing the Master Volume at the end of the signal chain. However, the Volume control is often placed closer to the pickups than the EQ Control, making it difficult to wire it directly to the output jack. In this case, no worries - reversing the order of the Master Volume and EQ control is acceptable.

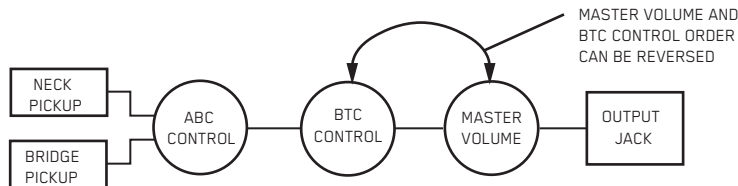

WARRANTY

All EMG Pickups and accessories are warranted for a period of two years. This warranty does not cover failure due to improper installation, abuse or damage. If upon examination the pickup is determined to be defective, a replacement will be made. Warranty replacement products are covered by this same warranty. This warranty covers only those pickups and accessories sold by authorized EMG Dealers. This warranty is not transferable.

**SPECIFICATIONS:
EMG Model: BTC-HZ System**

High Frequency (Treble) Response Selection:

The BTC allows you to choose from 4 different high frequency response curves. This is a nice feature, especially if you are using the BTC with passive pickups. Two DIP switches are located on the primary circuit board and can be adjusted immediately after installing the BTC, while the bass control cavity is still open.

The following diagrams show the DIP switch positions and resultant Treble frequency response curves.

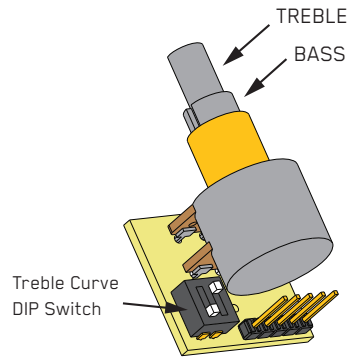

ON/ON



BELL CURVE WITH 2.0 kHz CENTER

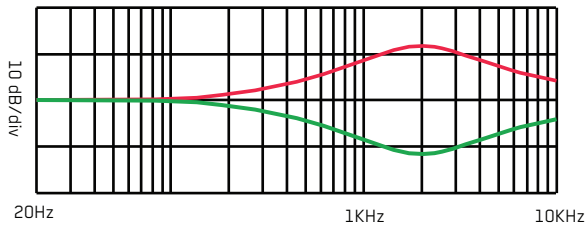

ON/OFF



BELL CURVE WITH 3.2 kHz CENTER

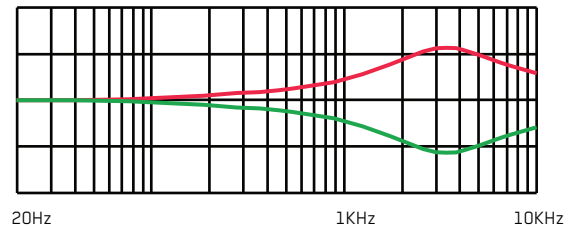

OFF/OFF



SHELF CURVE WITH 4.0 kHz CUTOFF

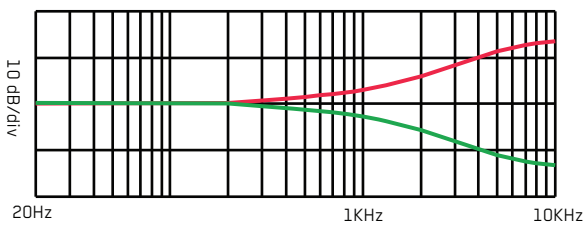

OFF/ON



SHELF CURVE WITH 1.6 kHz CUTOFF

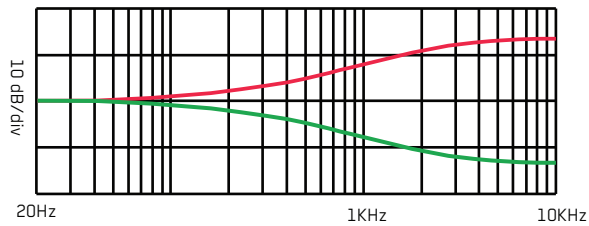

Low Frequency (Bass) Response:

The BTC has a fairly standard bass response boost and cut. It is a shelf curve with 6dB per octave slope and centered at 50 Hz. As seen in the graph to the right, the signal can be boosted by +12db (Red Line) or cut by -12dB (Green Line). A center detent (click) is provided on the control to let you know when the frequency response is flat / unaffected.

BTC CONTROL BASS RESPONSE

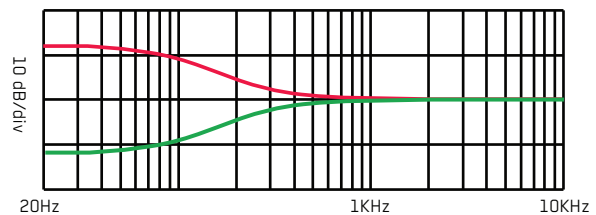

Installation Instructions:

Existing EMG-HZ Passive Pickup installations:

If you already have EMG-HZ Pickups in your instrument, check to see if the existing pickup cables already include solderless connectors or not.

In some cases, EMG-HZ Pickup cables may end in raw wires. This is common for EMG-HZ Pickups that came stock in certain instruments. A single black/white connection cable can be cut and spliced on either end to convert raw wires for use with the EMG solderless system. Diagram #2 depicts this for an EMG-HZ Pickup cable. For additional instructions on how to splice other types of passive pickup cables to a new EMG solderless connection header, refer to the separate instructions for B125 Active Balance Control, which can be found on its product page at emgpickups.com.

Otherwise, see Diagram #1 for solderless connections to the B125.

If you are using EMG P-HZ/J-HZ Pickups which came with a solderless Ground Buss, it will still be used as shown in the Pickup Instructions. Join the Ground Buss to an available Ground pin on the 25kΩ Volume Control included with this BTC-HZ System. If your EMG HZ Pickups did not come with a solderless Ground Buss, no additional ground connections are required.

Diagram #2
EMG HZ Pickup Cable - Hardwired

Solder the ground/shield wire of your pickup cable to the black wire of the EMG connect cable, and solder the signal or "hot" wire to the white wire.

Cover the connections with shrink tubing or use a suitable insulator to cover the connections.

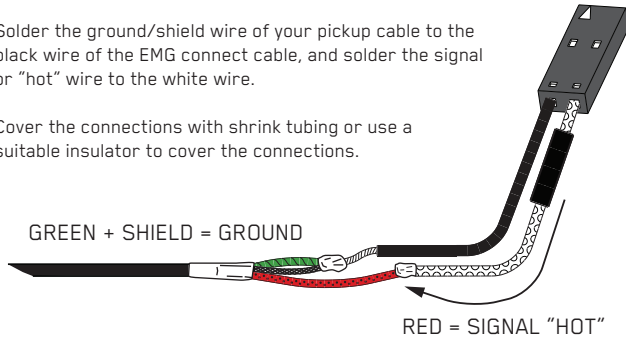

Diagram #1
EMG-HZ Pickups (Soapbar / Humbucker) into B125

Pins 1 and 4
These pins supply 9V+ for EMG Active Pickups:
DO NOT use either V+ pin when using passive pickups.

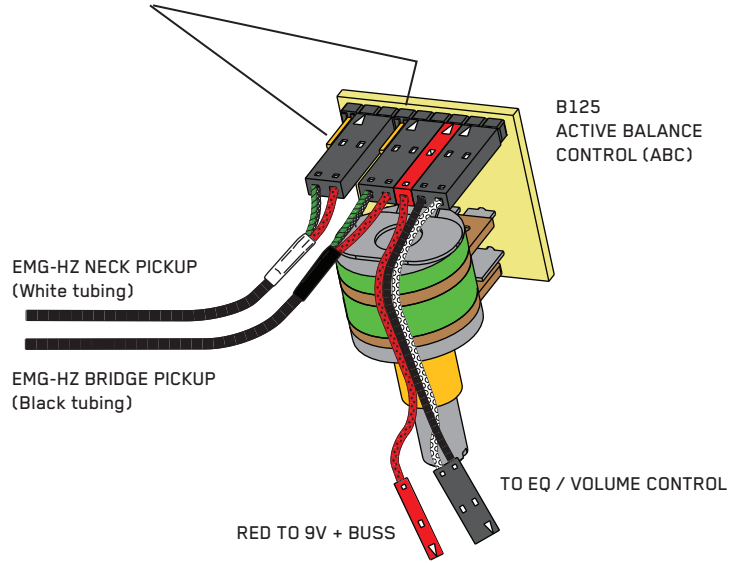

Diagram #3
2 Pickups / BTC-HZ System (Preferred Wiring Order)

This diagram depicts the preferred wiring order for the BTC-HZ System. If your control layout makes it impractical to connect the Master Volume directly to the output jack, you may reverse the order with the BTC Control. See Diagram #4 for this alternate wiring.

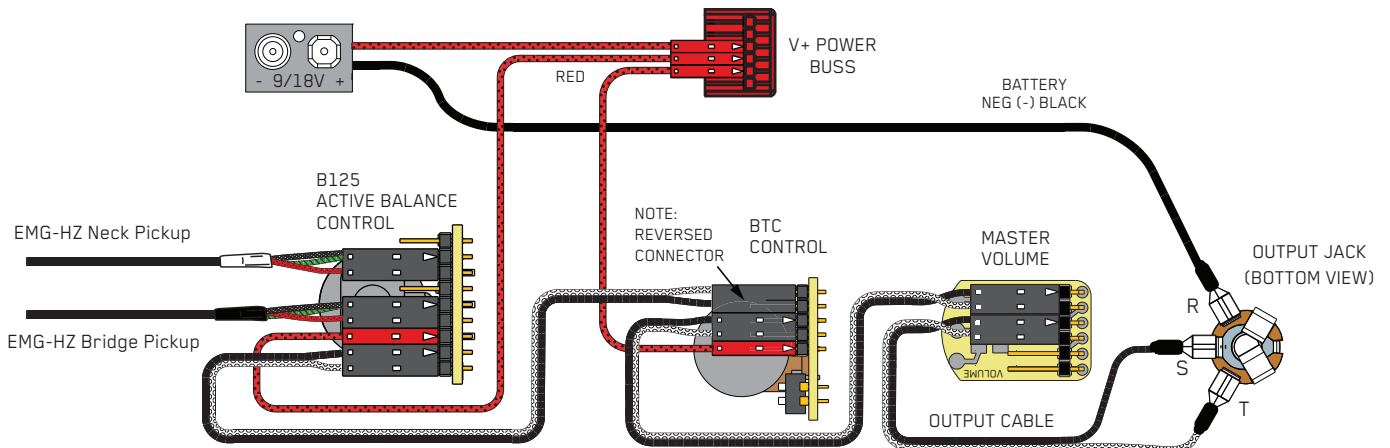
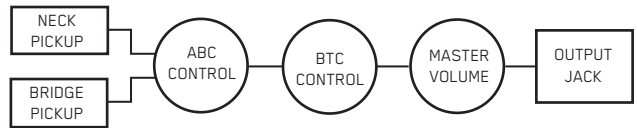

Diagram #4

2 Pickups / BTC-HZ System (Alternate Wiring Order)

This diagram depicts an alternative wiring method for the BTC-HZ System. This may be used when it is not practical to connect the Master Volume directly to the output jack.

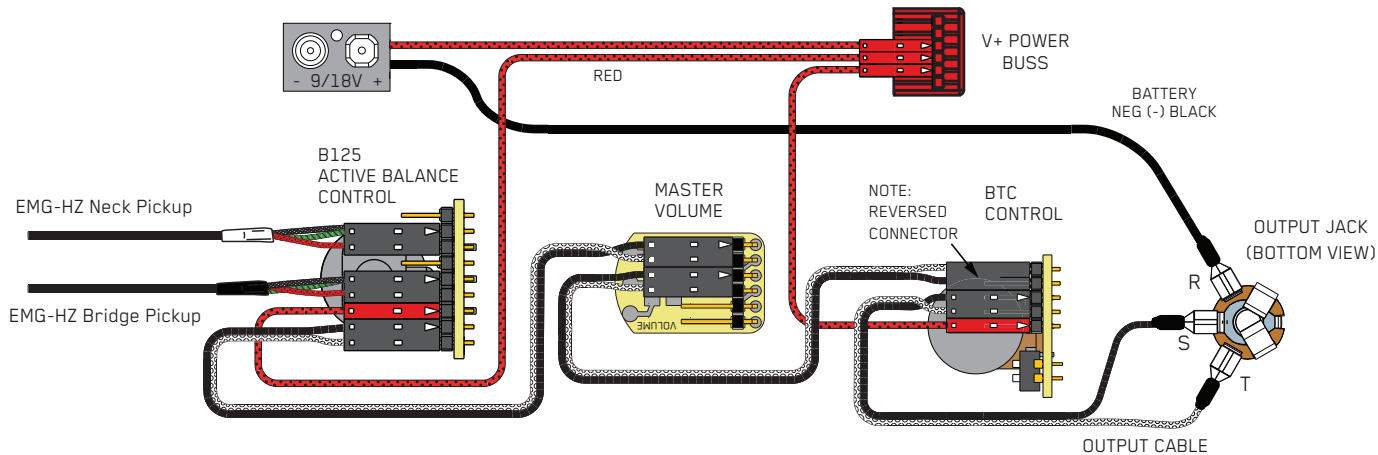
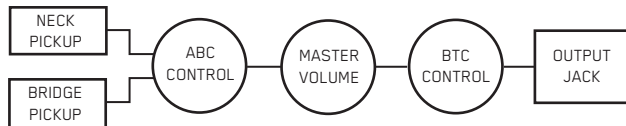

Diagram #7

If the instrument has a Battery Holder:

If your instrument has a 9 or 18 Volt battery holder you can still use the EMG Connectors to supply power to the System. Simply cut and strip the wires from the battery clip provided. Twist the wires together and use shrink tubing to cover the connections. Soldering the wires is preferred.

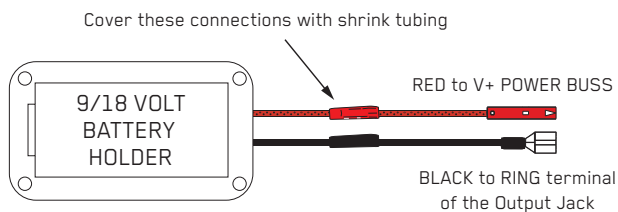
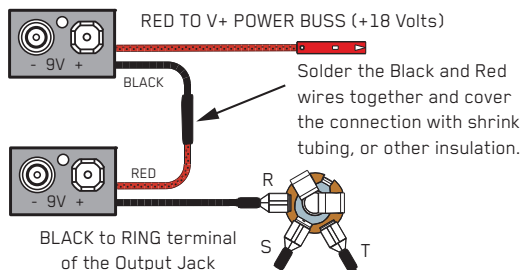

Diagram #8

+18 Volt Wiring Option (Soldered):

If you want to operate your instrument at +18 Volts for greater headroom and playing dynamics, use two battery clips wired in series as shown below. +18 Volts is recommended for any type of Active Accessory or EQ in your instrument which boosts the pickup signal. (BT, BQ, VMC, EXB, SPC, RPC, etc.)



COMPLIANCE



EMG Pickups and Accessories comply with the following regional certifications.

Region	Certification
Europe	CE, WEEE, REACH, RoHS
North America	RoHS
USA (California)	California Prop 65
UK	UKCA

ELECTRONIC PRODUCTS AND BATTERY DISPOSAL



All electrical and electronic products and batteries must be collected separately by a local collection system. Do not dispose of these items with your normal household waste. To prevent possible harm to the environment or human health from uncontrolled waste disposal, please recycle the product(s) responsibly.