



0230-0159-D

PO BOX 4394  
SANTA ROSA, CA  
95402 USA

P (707) 525-9941  
F (707) 575-7046  
EMGPICKUPS.COM

MAXIMUM STRING WIDTH 2.10"

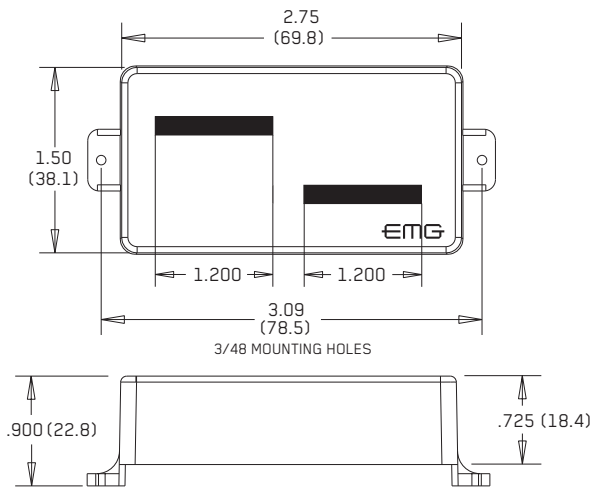

## INSTALLATION INFORMATION

### EMG MODEL: HB/HBCS

#### SPECIFICATIONS:

	MODEL:	HB	HBCS
Logo Color*		Silver	Silver
Magnet Type **		Ceramic	C/S
Resonant Frequency (KHz)		3.54	2.52
Output Voltage (String)		2.00	2.00
Output Voltage (Strum)		4.50	4.50
Output Noise (60 Hz)		-106	-96
Output Impedance (Kohm)		3	3
Current @9V (Microamps)		390	390
Battery Life (Hours)		1000	1000
Maximum Supply (Volts DC)		27	27

\*Note: Logo colors are not distinguished on metal caps

\*\*Note: Magnet type: C/S (Ceramic/Steel)

#### INSTALLATION NOTES:

The EMG-HB and HBCS are bass pickups in a standard guitar humbucking housing, designed for narrow width 4-string basses only.

The drawing above shows the maximum recommended string width.

All EMG Active Pickups are compatible with each other. EMG accessories, the VLPF, EXG, SPC or RPC Controls can be added to any EMG System without requiring an extra battery. EMG Pickups typically do not require string grounding, but you may connect your bridge ground wire to the metallic body of a volume or tone potentiometer. Use the included 25K Ohm controls for best results. If your output jack is a long panel style, you will need a stereo version, such as the SwitchCraft 152B, and soldering will be required (see the bottom of page 2). Adjust the pickup height to the strings, at a distance that works for you. Alternate wiring diagrams are available at [emgpickups.com](http://emgpickups.com).

#### INCLUDED WITH EACH PICKUP:

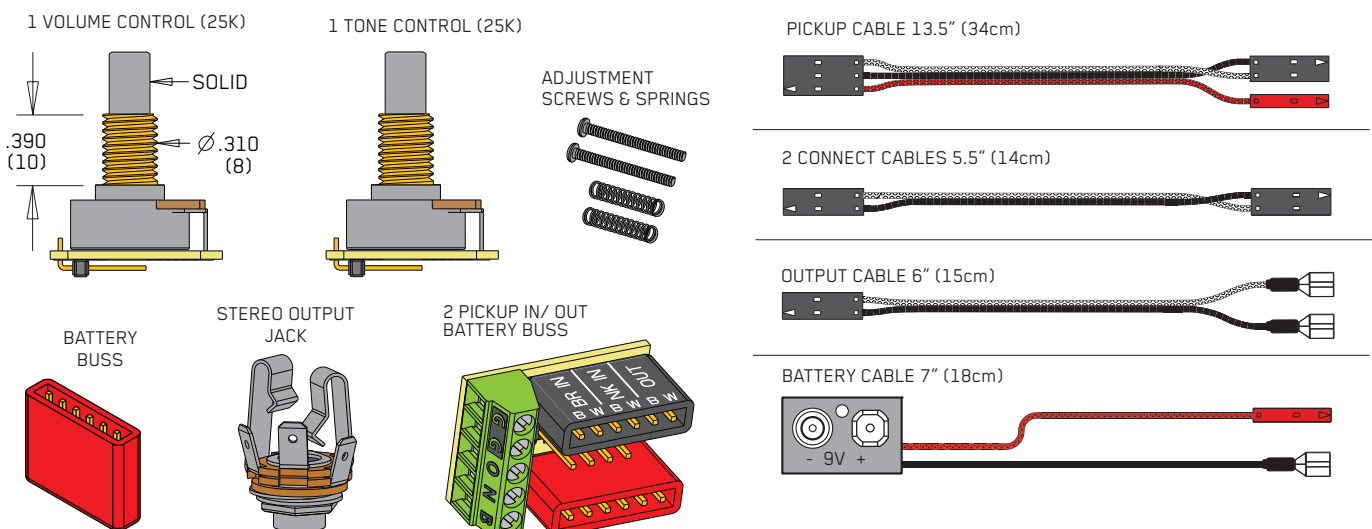

#### WARRANTY

All EMG Pickups and accessories are warranted for a period of two years. This warranty does not cover failure due to improper installation, abuse or damage. If upon examination the pickup is determined to be defective, a replacement will be made. Warranty replacement products are covered by this same warranty. This warranty covers only those pickups and accessories sold by authorized EMG Dealers. This warranty is not transferable.

## Installation Instructions:

### General Notes:

Every attempt has been made to make this a solderless installation.

There are some instances where this is not possible;

- 1) If your instrument uses the long panel output jack and you had passive pickups you will need a new stereo output jack, the Switchcraft 152B is recommended. Soldering to the new jack will be required, see Diagram #4 below.
- 2) Some instruments may already have a battery holder installed and in that case soldering may be required to the battery buss, see Diagram #5 below.
- 3) Instruments with two pickups may need soldering to the selection switch in some installations.

If you are installing only one pickup use the instructions on this page.

If you are installing two pickups go to Page 3 and begin there.

### Installation (One Pickup Guitars):

- 1) Plug the pickup cable onto the EMG Pickup header as shown in diagram #1 and route the cable to the control cavity. If the cable is too long, wind up the excess and keep it under the pickup if possible.

#### Master Volume control only

- 2) Refer to diagram #2. Plug both the Pickup cable and the output cable onto the Volume control as shown, then go to step 4.

#### Master Volume and Tone control

- 3) Refer to diagram #3. Plug the Pickup cable onto the Volume control as shown. Plug a connect cable from the Volume control to the Tone control. Plug the output cable onto the tone control as shown.
- 4) Connect the wires of the output cable to the output jack by pushing the connectors on as shown.  
WHITE wire to the TIP (T) contact,  
BLACK wire to the SLEEVE (S) contact  
BLACK Battery Negative wire to the RING (R) contact.
- 5) Using the battery buss, insert the RED wire of the pickup, and the battery RED wire. Extra pins can be used for EMG Accessories.
- 6) Put the battery in insulating foam and place it securely in the control cavity.  
We suggest that you plug in the instrument and test it before closing the control cavity.

#### \*\*\*\*Tips and Tricks\*\*\*\* Start your installation by:

- 1) Determining which type of output jack your instrument has.  
A Stereo 12B type is Included, but if you have a long panel jack, a SwitchCraft 152B Long Panel Jack will be required.
- 2) Remove the strings, remove any existing Pickups and controls (remember the order and function of each control)
- 3) Determine a good spot for the Pickup Buss and make sure the cable or wires from the selection switch will reach the Pickup Buss,
- 4) Install the EMG Volume and Tone Controls and tighten them in.
- 5) Install the pickups, keeping any excess cable under the pickup rather than in the control cavity.

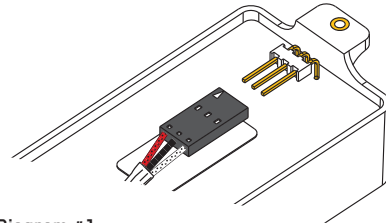

Diagram #1

Insert the plug onto the 3 pin header of the pickup as shown above.  
Note the orientation arrow.

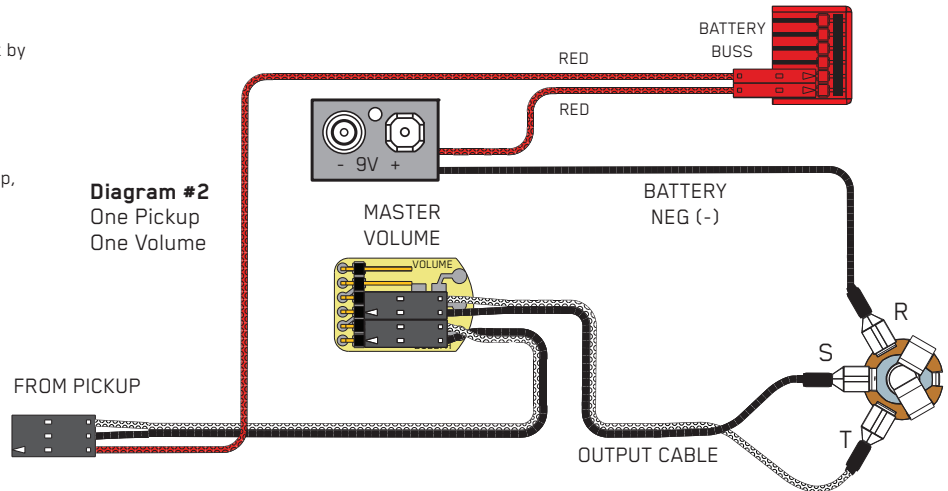

Diagram #2  
One Pickup  
One Volume

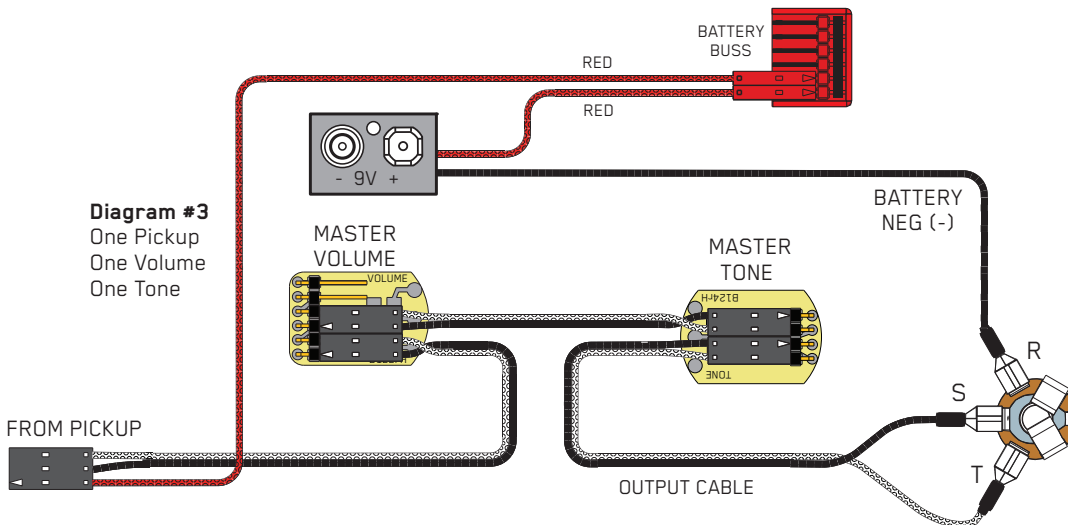

Diagram #3  
One Pickup  
One Volume  
One Tone

**Installation Instructions:**

**EMG Model: HB/HBCS**

**2 Pickups, 2 Volume controls and Master Tone, no selection switch**

**J-Bass Style wiring**

**Refer to Diagram #4**

- 1) Install the Pickups and route the Pickup cables to the control cavity.  
If the cables are too long, keep any excess under the pickup.
- 2) Mount the Volume and Tone controls into the body / pickguard.  
Plug the Neck Pickup Cable onto the Neck Volume control.  
Plug the Bridge Pickup Cable onto the Bridge Volume control.
- 3) Plug a connect cable from the Neck Volume control to the Bridge Volume Control.
- 4) Plug a connect cable from the Bridge Volume control the Master Tone control.
- 5) Plug the output cable onto the Master Tone control and connect the output wires to the output jack by pushing the connectors on as shown.  
WHITE wire onto the TIP (T) contact,  
BLACK wire onto the SLEEVE (S) contact,  
BLACK Battery Negative wire onto the RING (R) contact.
- 6) Plug the RED Wires of the pickups onto the V+ Supply Buss (RED Shroud) along with the RED of the battery clip.  
Extra pins on the V+ Battery Buss are for EMG Accessories.
- 7) Put the battery in a piece of insulating foam and place it securely in the control cavity. We suggest that you plug in the instrument and test it before closing the control cavity.

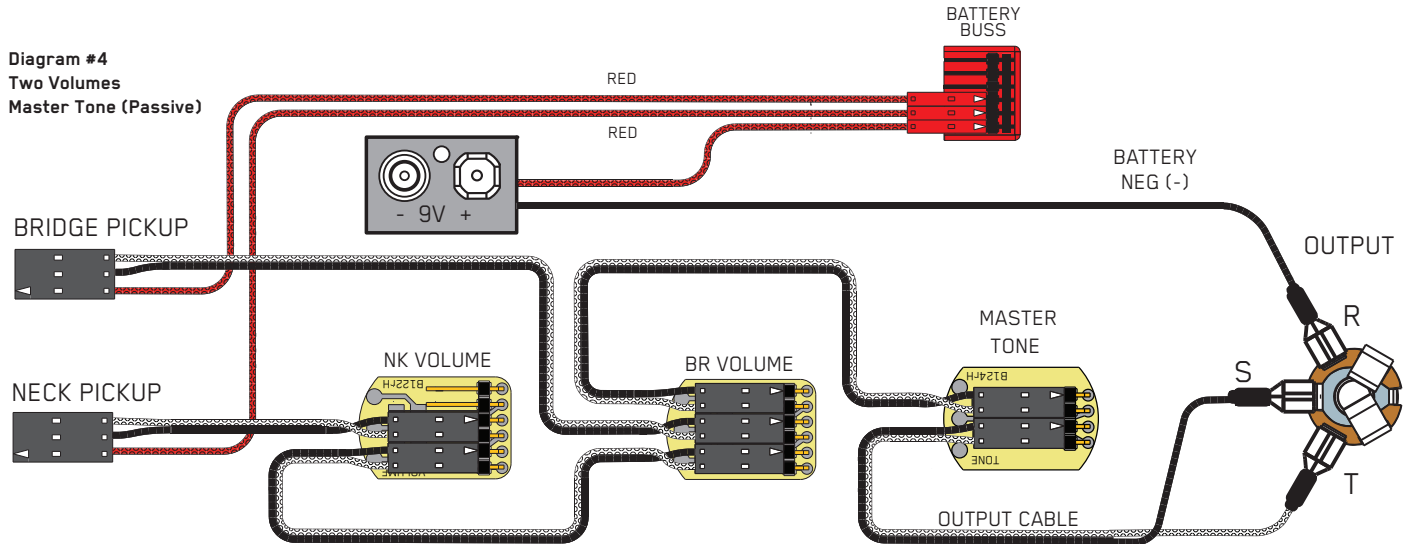

**If your instrument has a selection switch:**

Shown at the right is the EMG B245 Pickup Buss which is used for instruments that have 2 pickups and a 3 position selection switch.

If you have a selection switch and want your complete a solderless installation with the B245 Buss, please visit [emgpickups.com](http://emgpickups.com) for additional wiring diagrams.

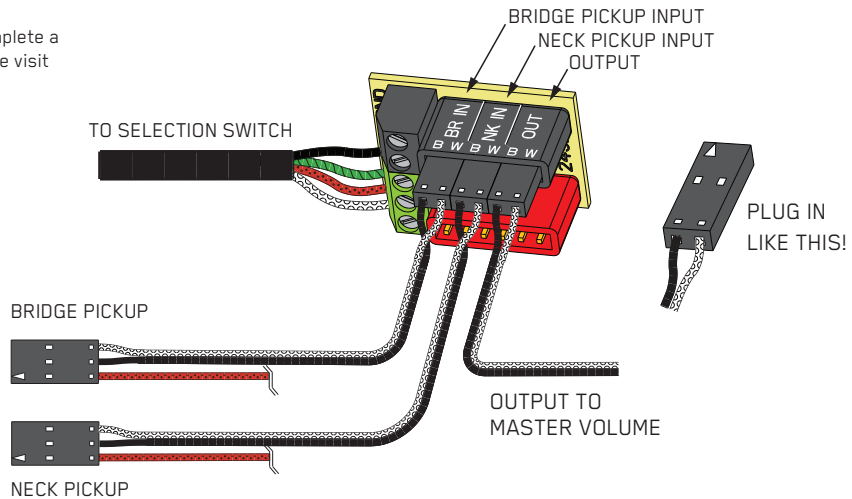

**Diagram #5**

**B125 Active Balance Control  
Master Volume / Master Tone**

This installation can be used for instruments with 3 control positions like the diagram above, but using a Balance control instead of 2 Volumes. The Tone Control shown in this diagram can be replaced with an EMG active accessory, such as the EXB Expander, BTC Control, and more.

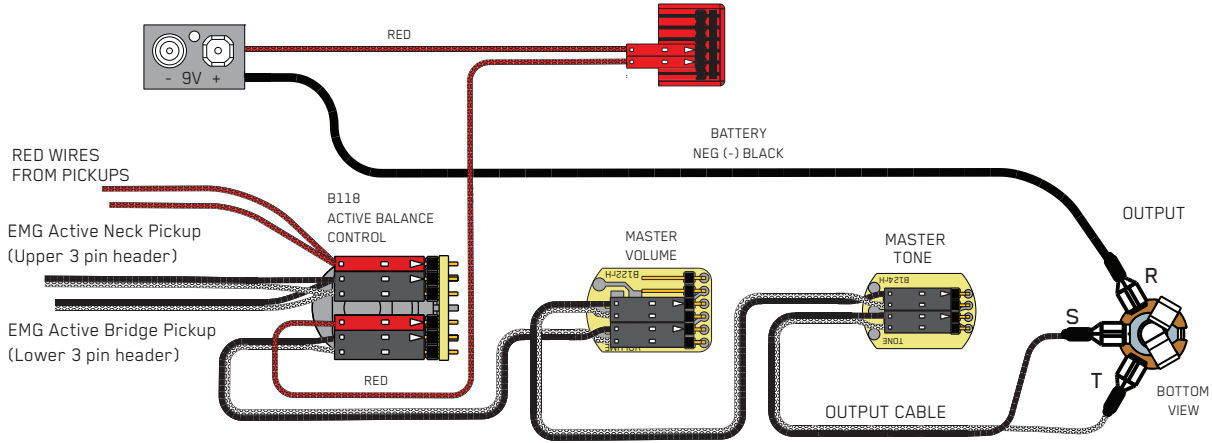
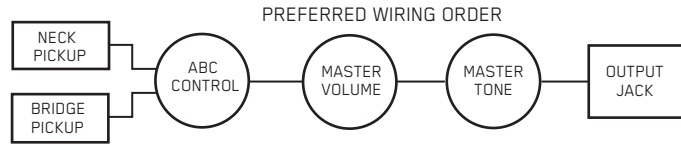

**Diagram #6**

**Soldering to the 152B Panel Jack:**

If your instrument has a long Panel Jack like the one below you will have to solder the output cable as shown. Ground (Black) to the Sleeve Battery Negative (Black) to the Ring Signal (White) to the Tip

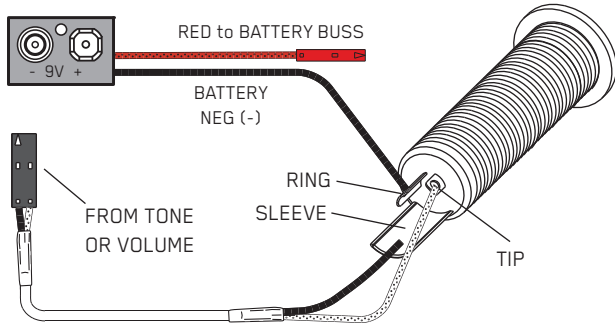

**Diagram #7**

**Soldering to the battery buss:**

If your instrument has an older EMG Pickup you can solder the pickup RED wire to the buss. Simply use some needle nose pliers, pull out the V+ header and solder the RED Wire from the pickup(s) to any of the pins in the header and then re-insert the header into the housing.

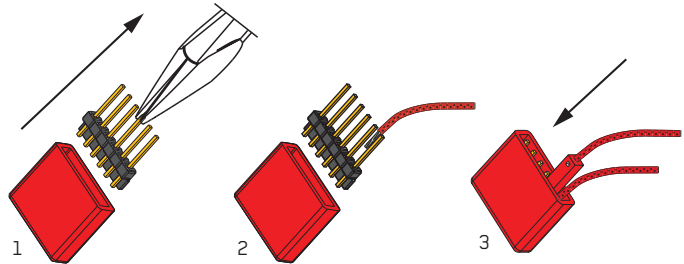

**Diagram #8**

**If the instrument has a Battery Holder:**

If your instrument has a 9 or 18 Volt battery holder you can still use the EMG Connectors to supply power to the pickups. Simply cut and strip the wires from the battery clip provided. Twist the wires together (Red to Red and Black to Black) and use the shrink tubing included to cover the connections. Soldering the wires is recommended.

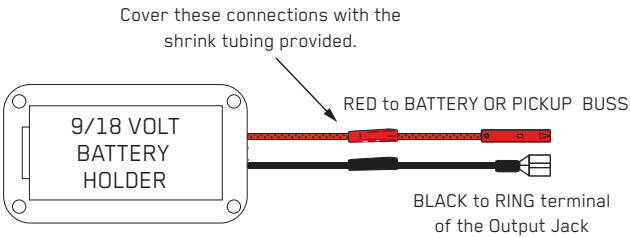

**Diagram #9**

**+ 18 Volt Wiring Option:**

If you want to operate your instrument at +18 Volts for more headroom then use 2 batteries wired as below. Also, if you are using any type of EQ in your instrument (EMG-BT, BQ) or anything that boosts the pickup signal then +18 Volts is recommended.

