



0230-03511B

PO BOX 4394  
SANTA ROSA, CA  
95402 USA

P (707) 525-9941  
F (707) 575-7046  
EMGPICKUPS.COM

**INSTALLATION INFORMATION**  
**EMG MODELS: DAVID ELLEFSON SIGNATURE SET**  
**35DC/35CS (4-STRING) 40DC/40CS (5-STRING)**

**SPECIFICATIONS:**

	<b>MODEL:</b>			
	35DC	35CS	40DC	40CS
Logo Color	Silver	Silver	Silver	Silver
Magnet Type *	C	C/S	C	C/S
Resonant Frequency (KHz)	4.85	3.95	4.55	3.75
Output Voltage (Finger, Thumb)	2.00	2.00	2.50	2.50
Output Voltage (Thump)	6.00	6.00	6.00	6.00
Output Noise (60 Hz)	-107	-109	-108	-108
Output Impedance (Kohm)	10	10	10	10
Current @9V (Microamps)	235	235	230	230
Battery Life (Hours)	1000	1000	1000	1000
Maximum Supply (Volts DC)	27	27	27	27

\*Note: Magnet Type: A (Alnico) C (Ceramic) C/S (Ceramic and Steel)

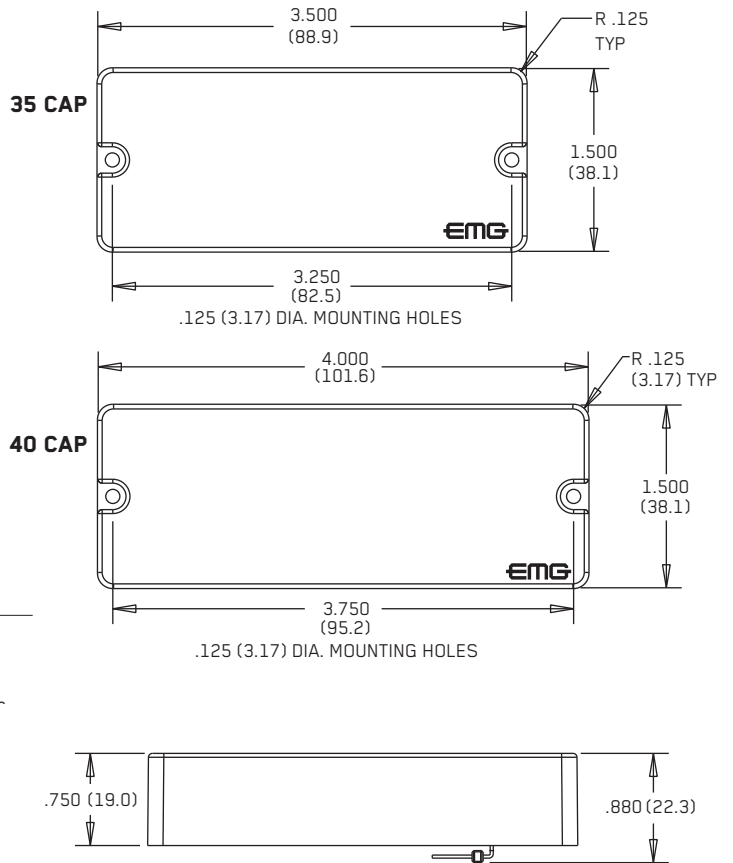

**PICKUP AND MAGNET DIMENSIONS:**

All EMG-35 and 40 Models have the housing dimensions (shown above).

The drawings below show the magnet placement for these versions. You should check the width of your strings against the magnet dimensions below to make sure there is sufficient string coverage. A rule of thumb for any pickup is that the total magnet width should be the string width plus twice the distance the pickup is from the strings. So, if the pickup is 3/16" (5mm) from the strings, with a magnet width of 2.90" (73.5mm) the maximum string width would be 2.50" (64mm). If your strings are too wide for the pickups shown below, choose one of the EMG-40 Extended Series Pickups, with a 4 inch (101mm) housing. If the pickup is 3/16" (5mm) from the strings, with a magnet width of 3.46" (88mm) the maximum string width would be 3.00" (76mm). If your strings are too wide for the pickups shown below, choose one of the EMG-45 Extended Series Pickups, with a 4.5 inch (114mm) housing, where similar styles of EMG pickups are available.

MAXIMUM RECOMMENDED STRING WIDTH 2.50" (63.5) ALL 35 MODELS

EMG-35CS/DC

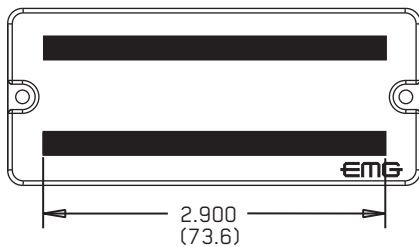

MAXIMUM RECOMMENDED STRING WIDTH 3.00" (76.2) ALL 40 MODELS

EMG-40CS/40DC

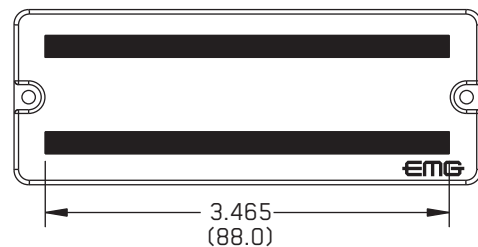

**WARRANTY**

All EMG Pickups and accessories are warranted for a period of two years. This warranty does not cover failure due to improper installation, abuse or damage. If upon examination the pickup is determined to be defective, a replacement will be made. Warranty replacement products are covered by this same warranty. This warranty covers only those pickups and accessories sold by authorized EMG Dealers. This warranty is not transferable.

**INCLUDED WITH EACH PICKUP SET:**

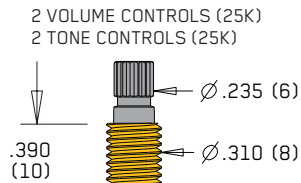

ADJUSTMENT SCREWS (2 pr)

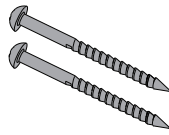

2 PICKUP CABLE 15" (38cm)



4 CONNECT CABLES 5.5" (14cm)



OUTPUT CABLE 6" (15cm)



BATTERY CABLE 7" (18cm)

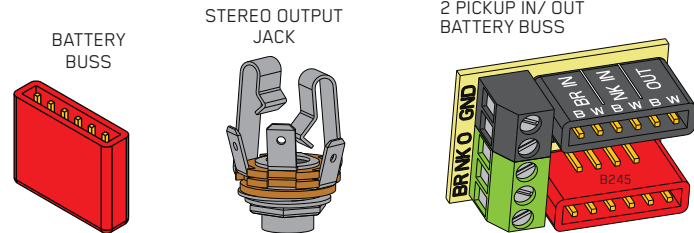

**Installation Instructions:  
EMG Models: DAVID ELLEFSON SIGNATURE BASS SET**

**General Notes:**

- Every attempt has been made to make this a solderless installation. There are some instances where this is not possible;
- 1) If your instrument uses the long panel output jack and you had passive pickups you will need a new stereo output jack, the Switchcraft 152B is recommended. Soldering to the new jack will be required, see page 4.
- 2) Power Supply tips are on page 4. If your instrument has a battery holder, you are installing this pickup with an older EMG, or you want to supply your instrument with +18 Volts, see page 4 for tips to avoid soldering.

If you are installing only one pickup use the instructions on this page.  
If you are installing two pickups go to page 3 and begin there.

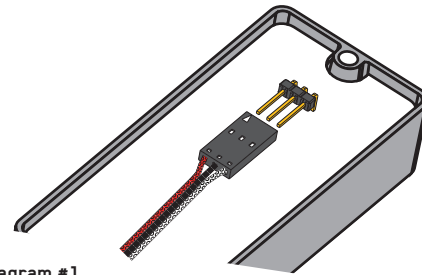

**Diagram #1**  
Insert the plug onto the 3 pin header of the pickup as shown above. Note the orientation arrow.

**Installation (One Pickup Guitars):**

- 1) Plug the pickup cable onto the EMG Pickup header as shown in Diagram #1 and route the cable to the control cavity. If the cable is too long, wind up the excess and keep it under the pickup if possible.

**Master Volume control only**

- 2) Refer to Diagram #2. Plug both the Pickup cable and the output cable onto the Volume control as shown, then go to step 4.

**Master Volume and Tone control**

- 3) Refer to Diagram #3. Plug the Pickup cable onto the Volume control as shown. Plug a connect cable from the Volume control to the Tone control. Plug the output cable onto the tone control as shown.

- 4) Connect the wires of the output cable to the output jack by pushing the connectors on as shown.

- WHITE wire to the TIP (T) contact,
- BLACK wire to the SLEEVE (S) contact
- BLACK Battery Negative wire to the RING (R) contact.

- 5) Using the battery buss, insert the RED wire of the pickup, and the battery RED wire. Extra pins can be used for EMG Accessories.

- 6) Wrap the battery in insulating foam and place it securely in the control cavity. We suggest that you plug in the instrument and test it before closing the control cavity.

**Diagram #2**  
One Pickup  
One Volume

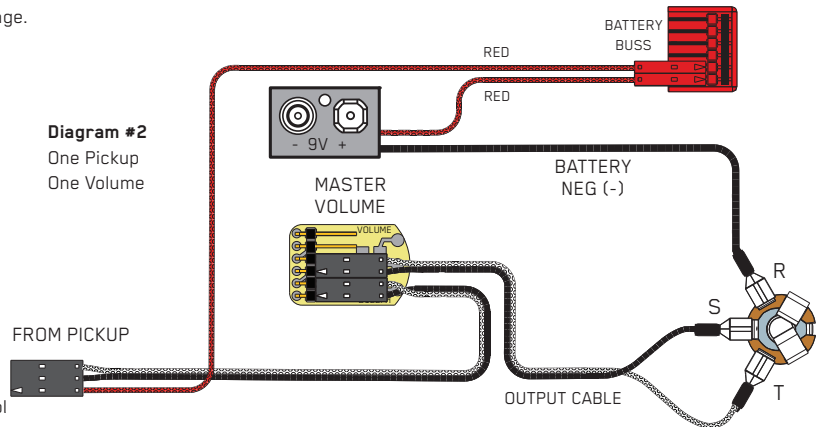

**Diagram #3**  
One Pickup  
One Volume  
One Tone

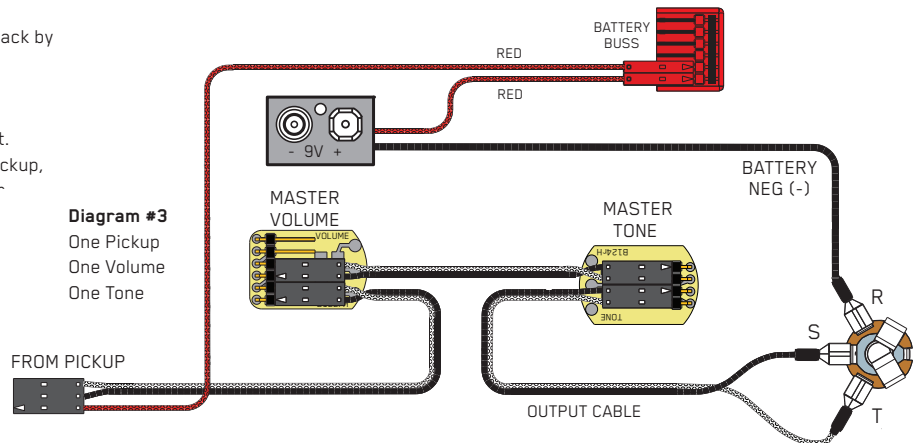

**Installation Instructions:**  
**EMG Models: DAVID ELLEFSON SIGNATURE BASS SET**

**2 Pickups, 2 Volume controls and Master Tone, no selection switch**

**J-Bass Style wiring**

**Refer to Diagram #4**

- 1) Install the Pickups and route the Pickup cables to the control cavity.  
 If the cables are too long, keep any excess under the pickup.
- 2) Mount the Volume and Tone controls into the body / pickguard.  
 Plug the Neck Pickup Cable onto the Neck Volume control.  
 Plug the Bridge Pickup Cable onto the Bridge Volume control.
- 3) Plug a connect cable from the Neck Volume control to the Bridge Volume Control.
- 4) Plug a connect cable from the Bridge Volume control the Master Tone control.
- 5) Plug the output cable onto the Master Tone control and connect the output wires to the output jack by pushing the connectors on as shown.  
 WHITE wire onto the TIP (T) contact,  
 BLACK wire onto the SLEEVE (S) contact  
 BLACK Battery Negative wire onto the RING (R) contact.
- 6) Plug the RED Wires of the pickups onto the V+ Supply Buss (RED Shroud) along with the RED of the battery clip.  
 Extra pins on the V+ Supply Buss are for EMG Accessories.
- 7) Wrap the battery in insulating foam and place it securely in the control cavity.  
 We suggest that you plug in the instrument and test it before closing the control cavity.

**\*\*\*\*Tips and Tricks\*\*\*\* Start your installation by:**

- 1) Determine which type output jack your instrument has.  
 A Stereo 12B type is Included, but if you have a long panel jack a SwitchCraft 152B Long Panel Jack will be required.
- 2) Remove the strings, remove any existing Pickups and controls (remember the order and function of each control)
- 3) Determine a good spot for the Pickup Buss and make sure the cable or wires from the selection switch will reach the Pickup Buss,
- 4) Install the EMG Volume and Tone Controls and tighten them in.
- 5) Then install the pickups keeping any excess cable under the pickup rather than in the control cavity.
- 6) **IMPORTANT: EMG Active pickups do not require a string ground wire! DO NOT Reconnect the string ground, it is unnecessary.**

**Diagram #4**

**Volume / Volume**

**Master Tone (Passive)**

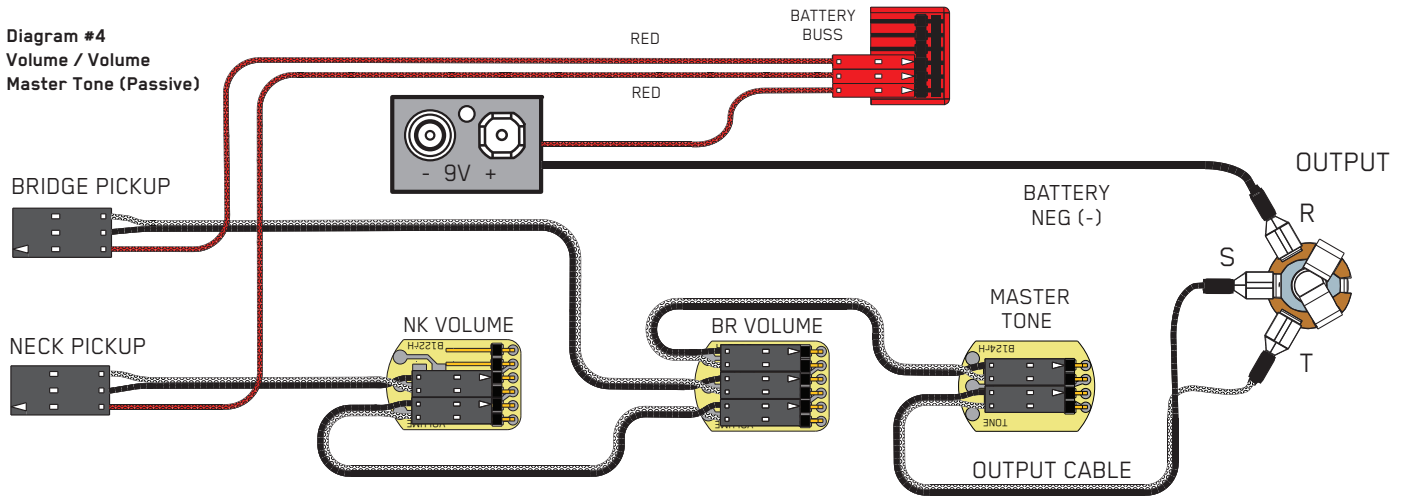

**If your instrument has a selection switch:**

Shown at the right is the EMG B245 Pickup Buss which is used for instruments that have 2 pickups and a 3 position selection switch. If you have a selection switch and want your installation to remain solderless, you'll need a B245 Buss. Either send an e-mail to: [sales@emgpickups.com](mailto:sales@emgpickups.com) or call: 800 821-1446 to get the buss.

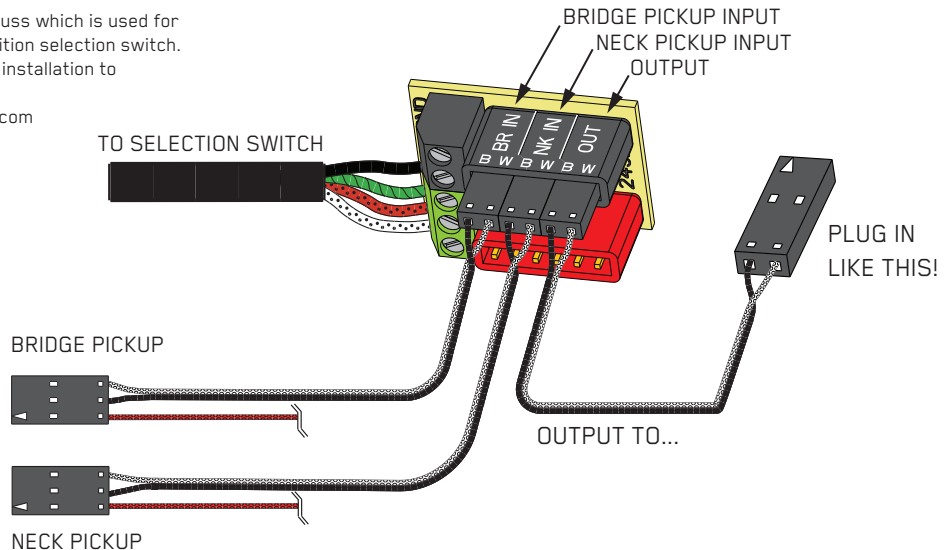

**Diagram #5**  
**B125 Active Balance Control**  
**Active Tone / Master Volume**

This installation can be used for instruments with 3 control positions like the diagram above, but use a Balance control instead of 2 Volume controls. Again, the EMG Active Tone Control shown in this diagram can be replaced with the EMG-EXB Expander, or the EMG-BTC.

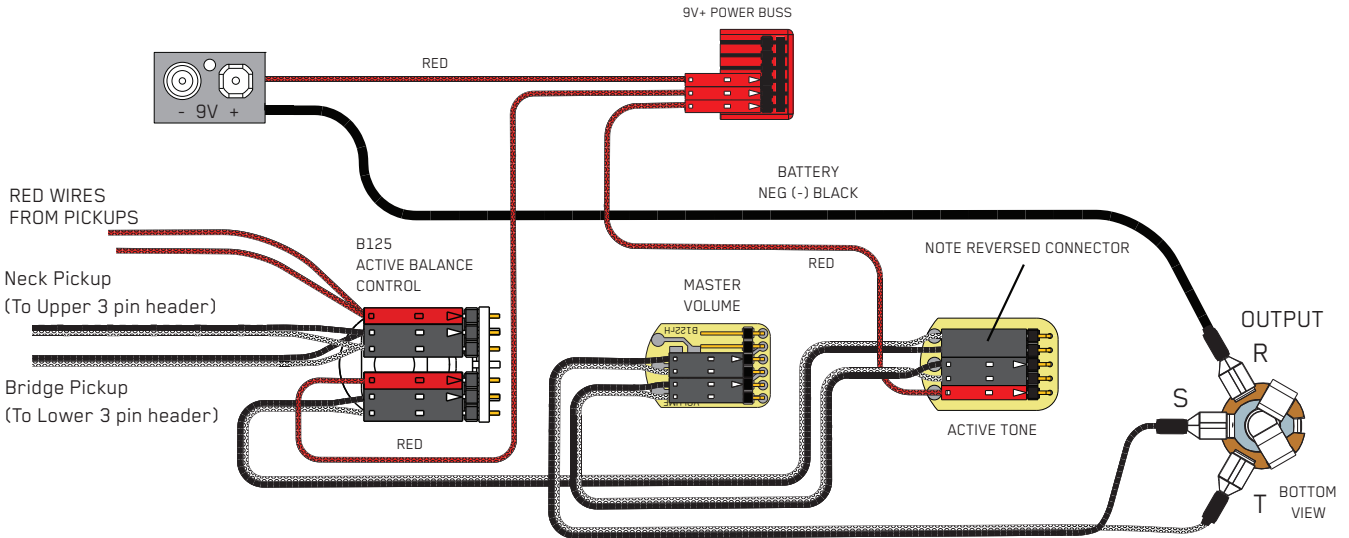
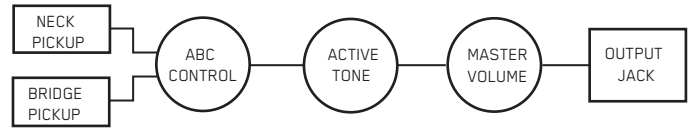

**Diagram #6**  
**Soldering to the 152B Panel Jack:**

If your instrument has a long Panel Jack like the one below you will have to solder the output cable as shown.  
 Ground (Black) to the Sleeve  
 Signal (White) to the Tip  
 Battery Negative (Black) to the Ring

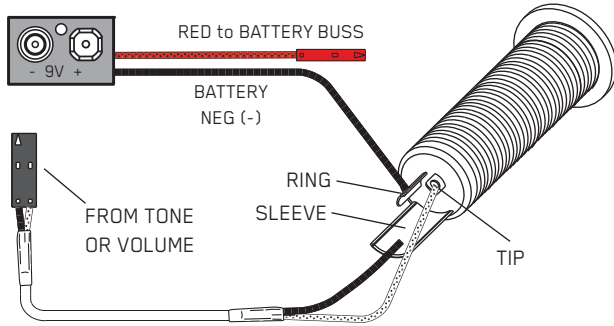

**Diagram #7**  
**Soldering to the battery buss:**

If your instrument has an older EMG Pickup you can solder the pickup RED wire to the buss. Simply use some needle nose pliers, pull out the V+ header and solder the RED Wire from the pickup(s) to any of the pins and then re-insert the header into the housing.

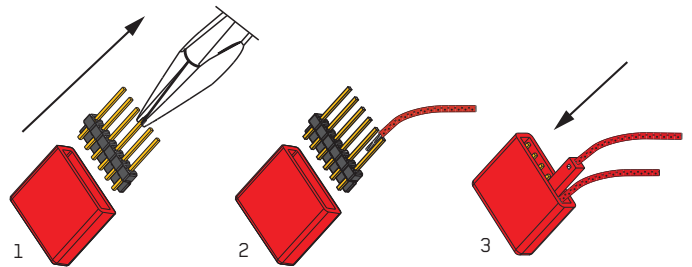

**Diagram #8**  
**If the instrument has a Battery Holder:**

If your instrument has a 9 or 18 Volt battery holder you can still use the EMG Connectors to supply power to the pickups. Simply cut and strip the wires from the battery clip provided. Twist the wires together (Red to Red and Black to Black) and use the shrink tubing included to cover the connections. Soldering the wires is recommended.

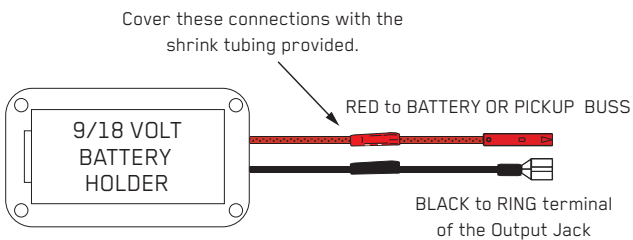

**Diagram #9**  
**+18 Volt Wiring Option:**

If you want to operate your instrument at +18 Volts for more headroom then use 2 batteries wired as below. Also, if you are using any type of EQ in your instrument (EMG-BT, BQ) or anything that boosts the pickup signal then +18 Volts is recommended.

