

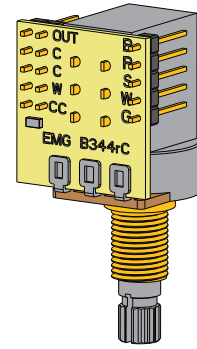

0230-0334rB

PO BOX 4394
SANTA ROSA, CA
95402 USA

P (707) 525-9941
F (707) 575-7046
EMGPICKUPS.COM



INSTALLATION INFORMATION

EMG MODEL: EMG-B344 SERIES/PARALLEL PUSH/PULL POT FOR PASSIVE HUMBUCKING PICKUPS

GENERAL OPERATION:

The B344 Series/Parallel Push/Pull Pot is designed for use on Dual-Coil Humbucking Pickups.

The Push/Pull switch lets you choose from Series (Normal) wiring to Parallel wiring to get a single coil sound from your humbucking pickup. The Pot portion of the control is 500K Ohm and can be used as either a volume control or a tone control for a pickup or as a master volume or tone control.

All EMG Humbucking pickups feature a 5 wire Connection and have a solderless installation.

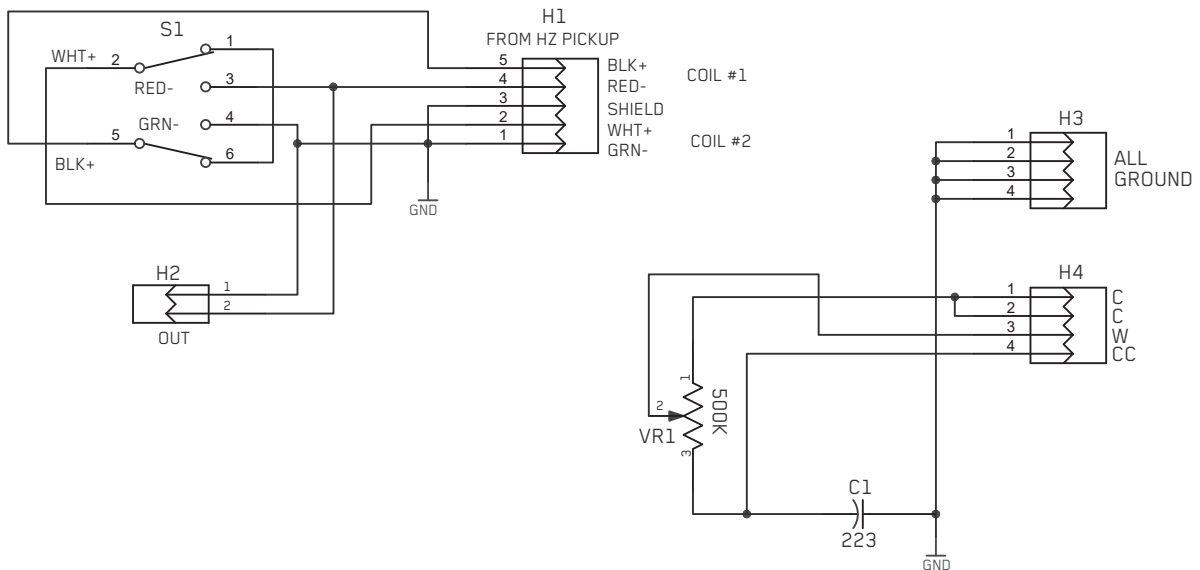
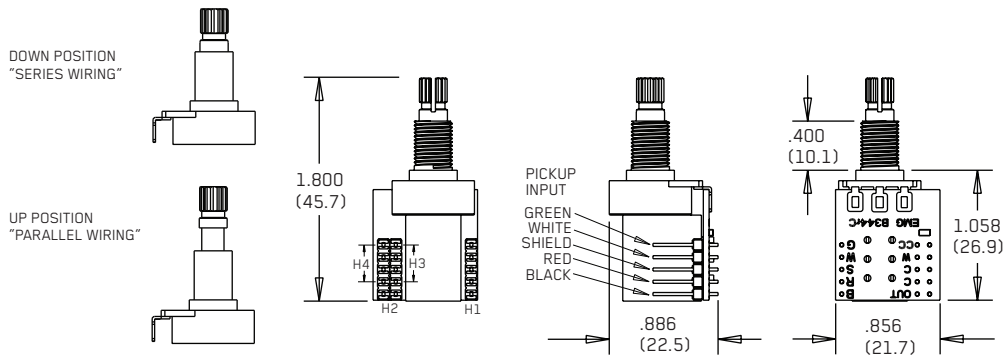

Installation Instructions:
EMG Model: B344 SERIES/PARALLEL SWITCH
PUSH/PULL POT

The B344 Series/Parallel Control should be thought of as 2 separate components. The Series/Parallel switching is operated by the up/down motion switching of the pot shaft. The 500K Potentiometer can be used as a volume or tone for the pickup, or can be used as a Master Volume or Master Tone Control for the instrument. It depends on how your instrument is wired.

The 5 wires from the pickup are routed to the input section of the switch, then the output of the switch can be routed directly to the pot, as a volume or tone control or you can send the output of the of the pickup to the selection switch.

If the diagram you need isn't shown, contact EMG customer service and we'll help you out.

Diagram #1
 Insert the connectors as shown and be sure to follow the color code on the PC Board.

Diagram #1

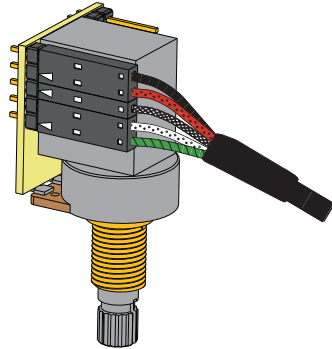

Diagram #2

If you are mixing the EMG Pickup with another type of pickup and they are "Out of Phase" you can simply reverse the Red/Black and Green/White connectors and this will reverse the phase of the pickup.

Diagram #2

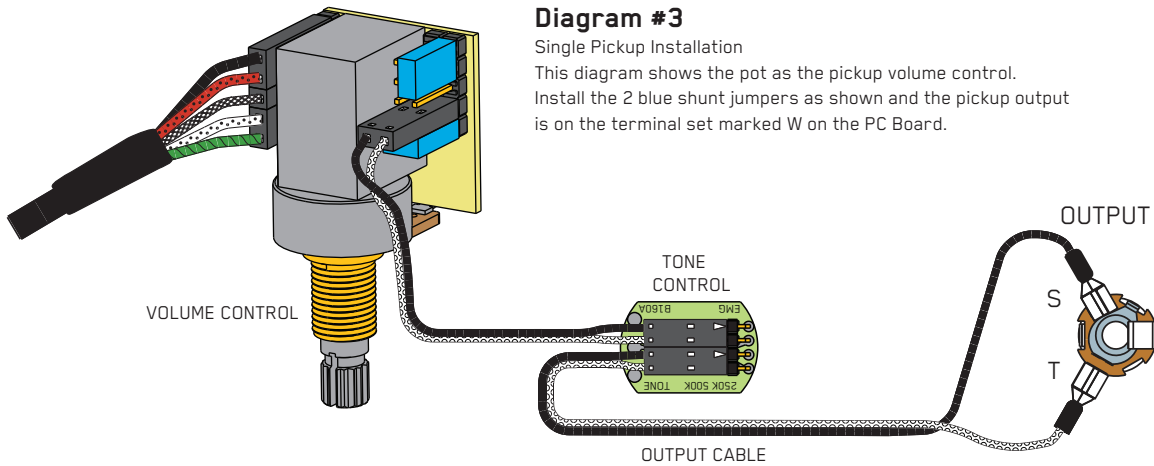
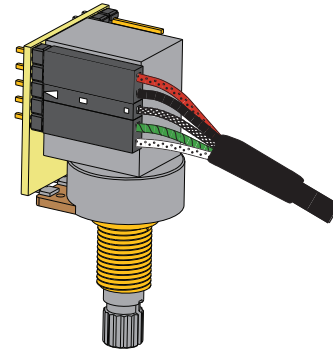

Diagram #3

Single Pickup Installation
 This diagram shows the pot as the pickup volume control. Install the 2 blue shunt jumpers as shown and the pickup output is on the terminal set marked W on the PC Board.

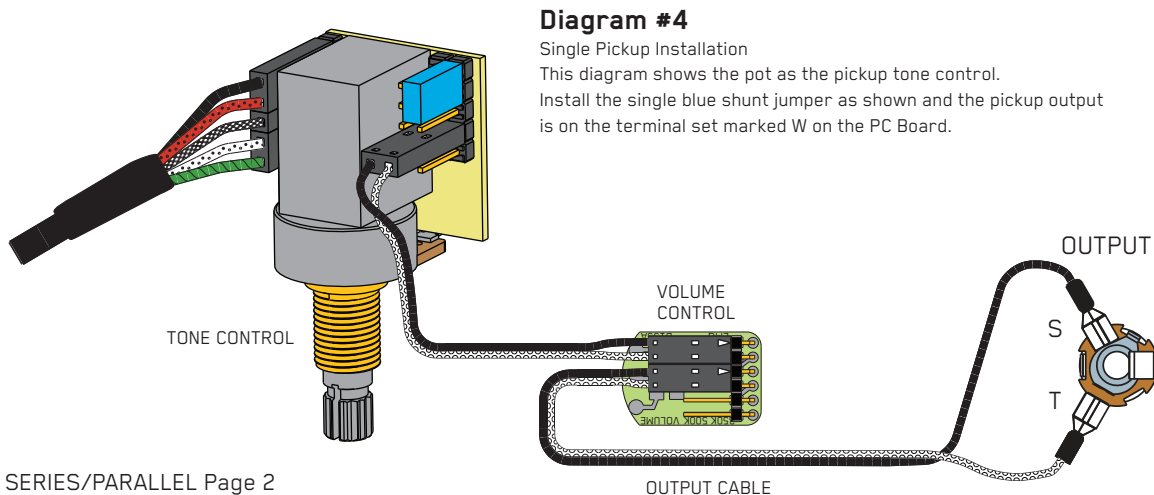

Diagram #4

Single Pickup Installation
 This diagram shows the pot as the pickup tone control. Install the single blue shunt jumper as shown and the pickup output is on the terminal set marked W on the PC Board.

Volume/Volume/Tone:

Diagram #5

Two Pickup Installation

This diagram shows two push/pull pots both acting as volume controls in a daisy-chain arrangement with a master tone for the instrument.

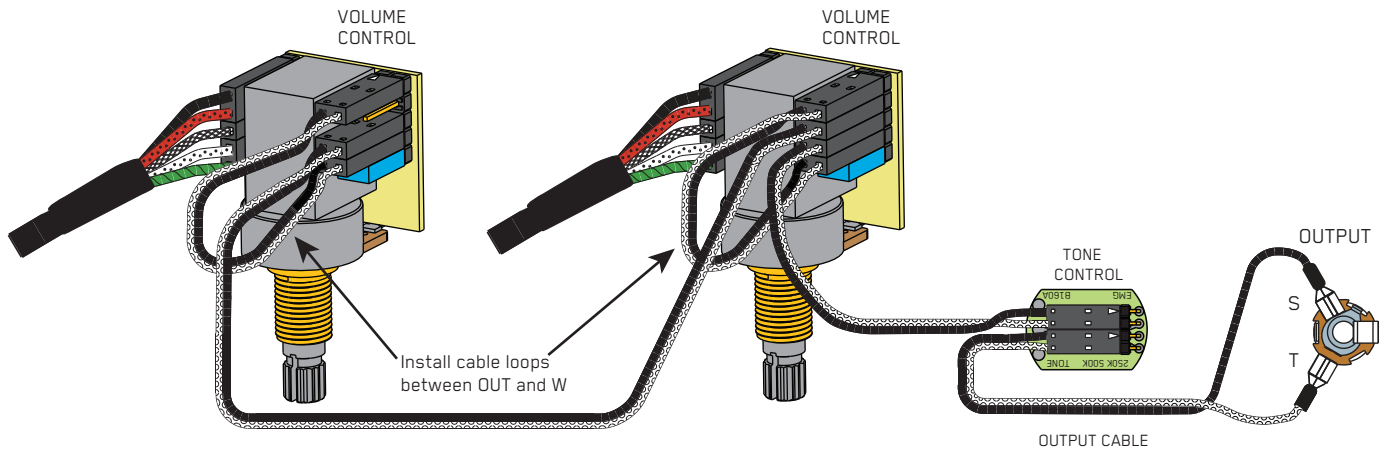

Diagram #6

Two Pickup Installation

This diagram shows two push/pull pots both acting as volume controls. Along with tone controls for each pickup.

