



0230-0077J

PO BOX 4394
SANTA ROSA, CA
95402 USA

P (707) 525-9941
F (707) 575-7046
EMGPICKUPS.COM

X-SERIES

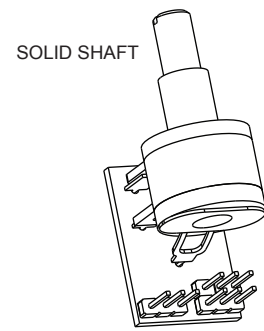

INSTALLATION INFORMATION
EMG MODEL: **B118 ACTIVE BALANCE CONTROL / ABC-X**
(ACTIVE PICKUP INPUT ONLY)

SPECIFICATIONS

Input Impedance (Ohms)	25K
Input Referred Noise	-130dbV
Output Impedance (Ohms)	2K
Current @ 9V (Microamps)	188
Battery Life (Hours)	2500
Maximum Supply (Volts DC)	18

INCLUDED:

- 1 B118 ABC Control
- 1 25K Solid Shaft Pot (Master Volume SPL/SOL)**
- 1 Active Tone Control (VLPF)**
- 2 Interconnect cables (1 Red, 1 White)

** Included with your EMG X Pickup.

GENERAL OPERATION:

The B118 Active Balance Control (ABC) is used to pan between two Active EMG pickups rather than use a selection switch. The input impedance of the B118 is designed for EMG Active Pickups only, yielding a lower noise factor and lower current drain. Pickups can be connected by either connectors or hand soldered to the PC board. The control has a center detent (click) in its rotation. If you have Passive Pickups, or are mixing an active with a passive pickup, you will want to use the B125 Active Balance control which features input buffer amps for each pickup.

INSTALLATION NOTES:

The output impedance of the ABC is low, so the existing passive tone control will not work when placed after the ABC. The active tone control (VLPF) is required for tone. Any of the EMG accessories like the EXB, BTC or BTS Controls, BQC or BQS Controls, or OEM Models B30eq or B64eq can be used in place of the VLPF.

**Dimensions:
B118 Active Balance
(ABC)**

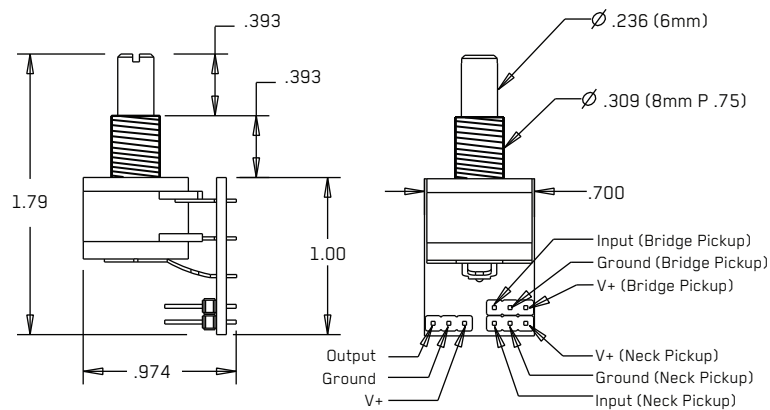

WARRANTY

All EMG Pickups and accessories are warranted for a period of two years. This warranty does not cover failure due to improper installation, abuse or damage. If upon examination the pickup is determined to be defective, a replacement will be made. Warranty replacement products are covered by this same warranty. This warranty covers only those pickups and accessories sold by authorized EMG Dealers. This warranty is not transferable.

Installation Instructions:
EMG Model: B118 ABC (Active Balance Control)

If you already have EMG Active Pickups in your instrument you can use the existing pickup cables or you can use the new pickup cables provided. The new cables feature connectors on both ends to make the installation easier. If you are using a PA-2 Booster or a Pi-2 phase switch on one pickup, see diagram #6 on page 4. Read through these instructions and then make the decision to use the existing cables or the new cables provided.

Plug-in inputs:

Diagram 1 illustrates how to connect the pickups to the ABC Control by using the EMG plug-in connectors. Diagram 2 shows how to solder the pickups to the PC Board.

Diagram #1
EMG Active Pickups:
Connector input

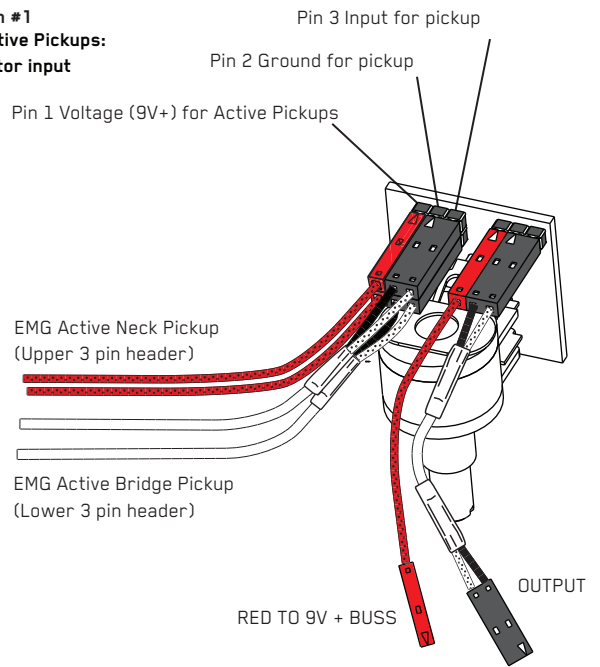

Soldered inputs:

On the back side of the ABC PC Board there are 4 pads to solder to. Solder the signal wire (Hot) of the bridge pickup to the BRG Pad, and solder the ground wire (shield) of that pickup to the GND Pad.

Do the same for the Neck Pickup, Hot to the NEK Pad, and ground to the GND Pad.

Powering up the pickups:

If you use the plug-in inputs, like above, the power for the pickups is supplied from the B118 PC Board. When you use the soldered inputs you will need to power the pickups with the power buss. Since your existing pickup cables don't have the connector for the power buss, simply use some needle nose pliers and pull out the V+ header and solder the RED Wires of the EMG Pickups to any of the pins on the header. Also, don't forget to solder the RED Wire of the battery clip to one of the header pins of the buss as well.

Diagram #2
EMG Active Pickups
Soldered Inputs

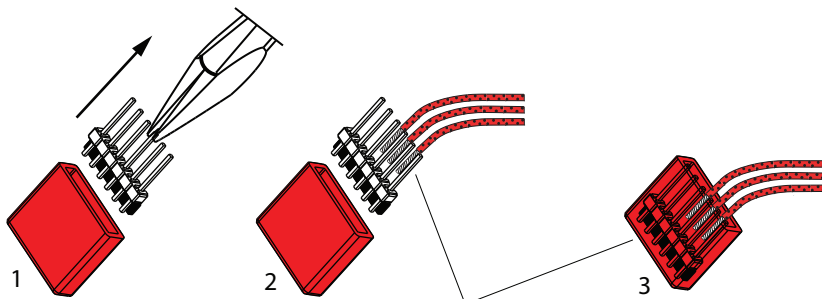
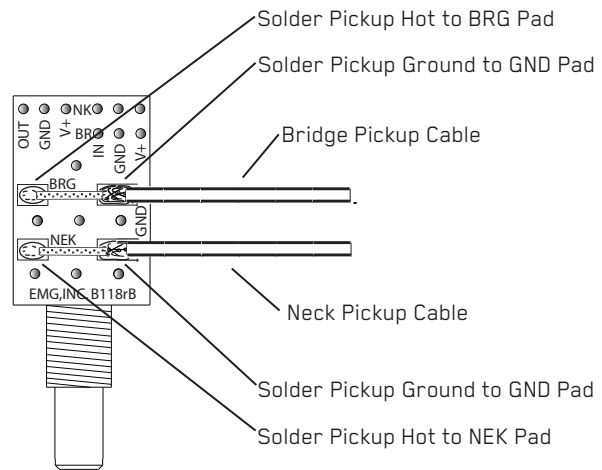

Solder RED wires from both EMG Pickups and the RED wire of the Battery Clip and re-insert the Header into the insulation cover

Output of the ABC Control:

The output of the ABC is a single channel signal that is sent to a master volume and active tone.

If you want a standard tone control (high end roll off) use the EMG-VLRF.

The following diagrams show any EMG "Active Tone" control being used i.e. VLRF, EXG, BTC Control, BTS Control, BQC Control, BQS Control, or any of EMG's OEM Controls like the B30EQ or B64EQ.

Preferred wiring order:

Below is a block diagram showing the preferred wiring order of the controls.

- 1) ABC Balance Control
- 2) Active tone control
- 3) Master Volume
- 4) Output jack

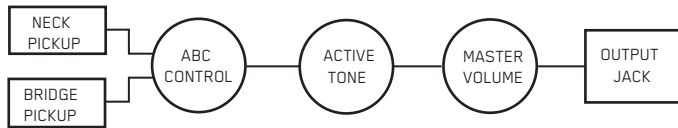

All of the EMG Active controls use the same color coded connector shown below.

Note: Reversed connector!
Make sure the colors of the wires match the color legend on the PC Board.

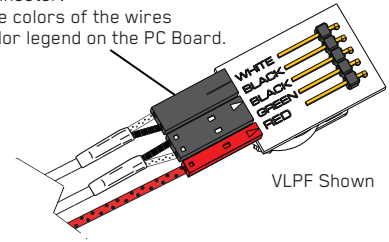

Color Code for EMG Active Tone controls and accessories.

- White: Input
- Black: Ground for Input
- Black: Ground for Output
- Green: Output
- Red: V+ Supply

Diagram #3 (preferred wiring order)
ABC Control / Active Tone / Master Volume / Output Jack

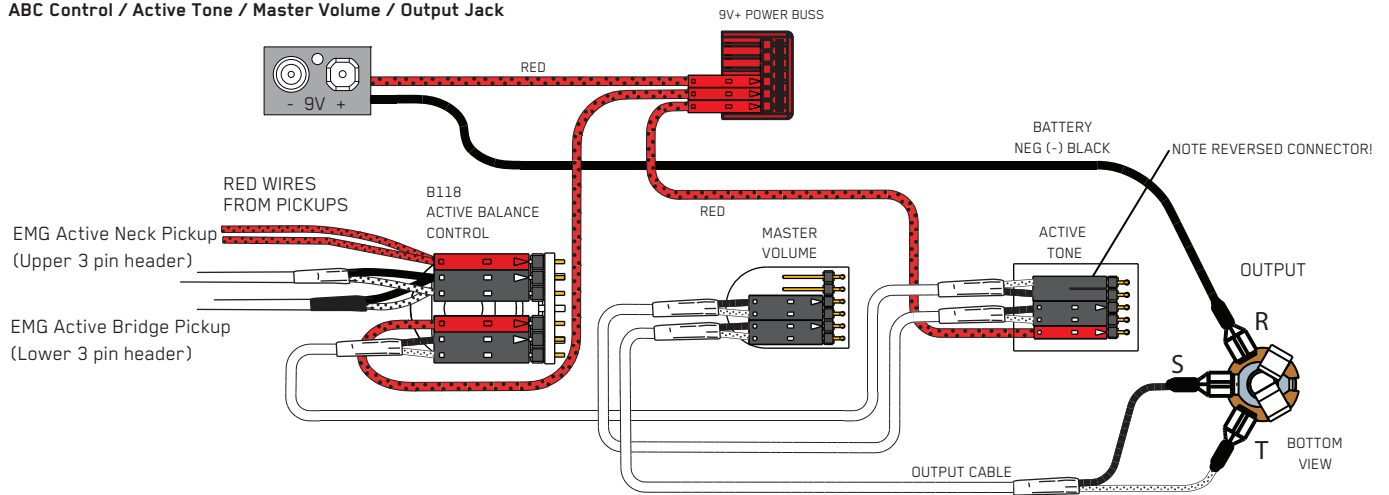

Alternate wiring order:

- 1) ABC Balance Control
- 2) Master Volume
- 3) Active Tone Control
- 4) Output jack

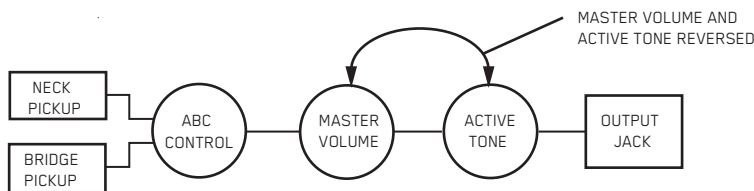
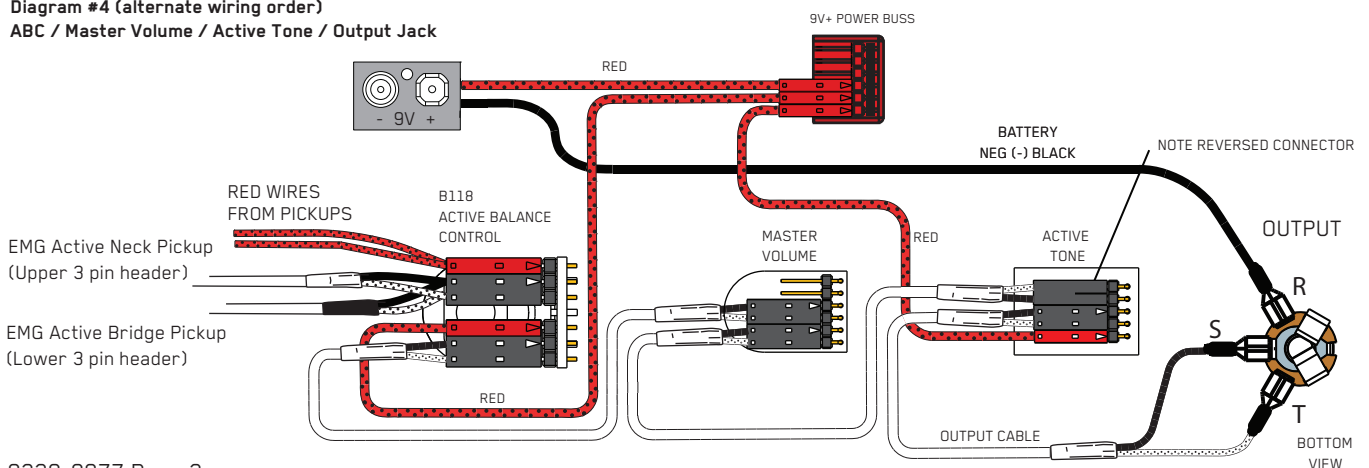

Diagram #4 (alternate wiring order)
ABC / Master Volume / Active Tone / Output Jack



Add another tone control:

- 1) ABC Balance Control
- 2) Active Tone Control #1
- 3) Active Tone Control #2
- 4) Master Volume
- 5) Output jack

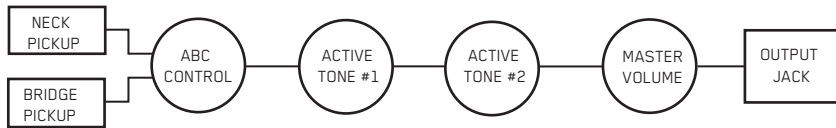
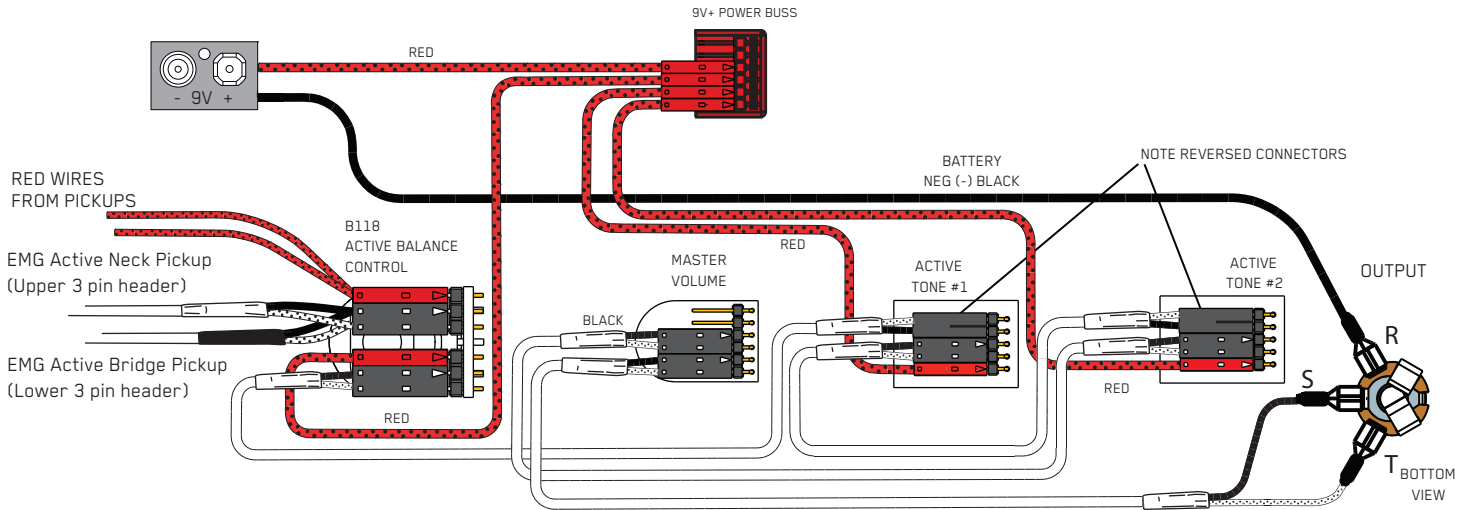

Diagram #5 (preferred wiring order)

ABC Control / Active Tone #1 / Active Tone #2 / Master Volume / Output Jack



Add an accessory on one pickup only:

- 1) Pickup into an EMG Accessory (Pi2 shown)
- 2) ABC Balance Control
- 3) Active Tone Control
- 4) Master Volume
- 5) Output jack

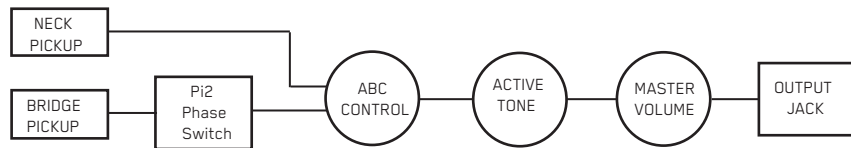

Diagram #6

Adding an accessory before the ABC Bridge Pickup to Pi2

