

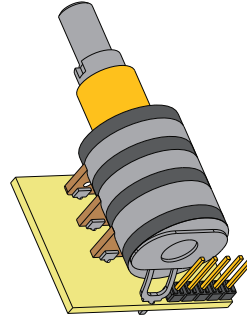

0230-0220rB

PO BOX 4394
SANTA ROSA, CA
95402 USA

P (707) 525-9941
F (707) 575-7046
EMGPICKUPS.COM



INSTALLATION INFORMATION EMG MODEL: **EMG-VMC CONTROL**

SPECIFICATIONS

Input Impedance (Ohms)	500K Ohm
Gain/Attenuation/ Mid Frequency Control	+/- 12db/(Adjustable)
Input Referred Noise	-120dbV
Output Impedance (Ohms)	2K
Recommended Supply Voltage	18 Volts
Current @ 9V/18V (Microamps)	600/740
Battery Life (Hours)	750
Maximum Supply (Volts DC)	27 Volts

INCLUDED:

- 1 VMC Control
- 1 Set Concentric Knobs
- 1 Battery Clip with Buss Connector
- 1 Stereo Output Jack (Battery Switching)
- 4 Interconnect Cables (2 Red, 2 White)

GENERAL OPERATION

The EMG-VMC is an active EQ Circuit for bass and guitar. Its effects are illustrated in the graphs on Page 2. Rotate the upper control clockwise for boost, counterclockwise for cut. Leave it in the center detent position for flat response. Rotate the frequency knob to sweep through the mid-frequency band from 100 Hz to 1000 Hz. The VMC can be used in combination with the EMG-BT (Bass/Treble) controls as well as any of the other EMG accessories. It uses EMG's typical 5 pin connector for simple installation.

Dimensions:

BTC (Bass/Treble) Equalizer

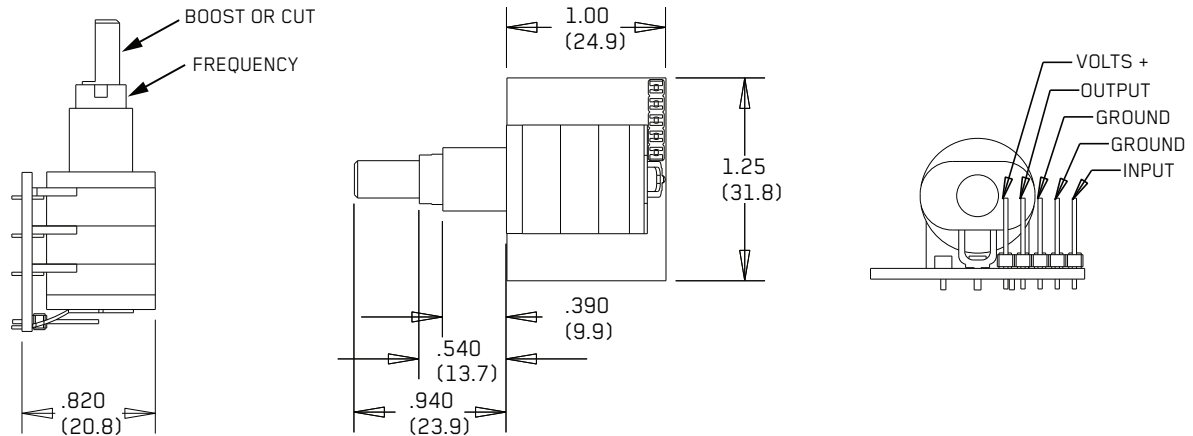

WARRANTY

All EMG Pickups and accessories are warranted for a period of two years. This warranty does not cover failure due to improper installation, abuse or damage. If upon examination the pickup is determined to be defective, a replacement will be made. Warranty replacement products are covered by this same warranty. This warranty covers only those pickups and accessories sold by authorized EMG Dealers. This warranty is not transferable.

Installation Instructions:
EMG Model: VMC Control

Mid Frequency Selection:

The lower control of the VMC allows you to choose the mid-range frequency to effect either boost or cut. The upper control of the VMC effects the amount of boost or cut of the chosen frequency effects the amount of boost or cut of the chosen frequency and has a center detent for flat frequency response, or no effect from the VMC Control.

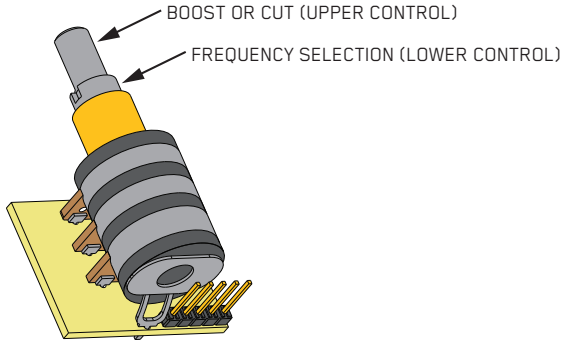

VARIABLE MID-RANGE FREQUENCY

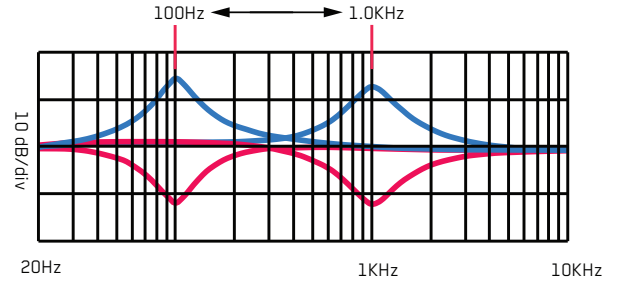

VARIABLE MID-RANGE CUT

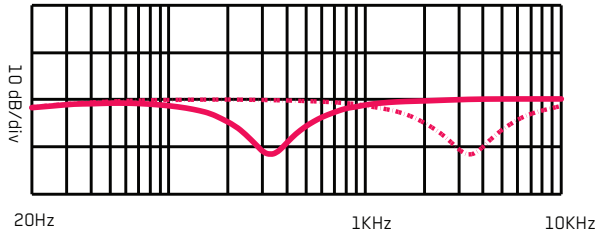

VARIABLE MID-RANGE BOOST

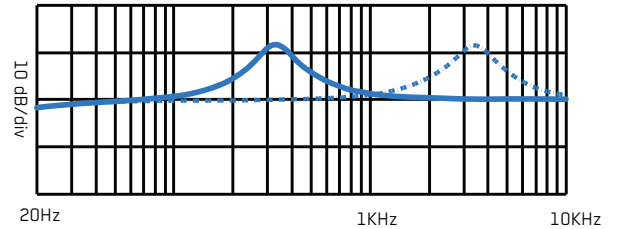

The VMC Control is easily installed by using the connector cables supplied. Diagram #1 shows the cables connected to the VMC Control. This 5-pin layout is the same for all EMG Accessories, so they can be interchanged.

There are a variety of ways instruments can be wired. The examples shown here are only a few. If your instrument has different wiring than shown here go to our website: <http://www.emgpickups.com> for alternate diagrams.

Diagram #2 below shows the installation of a single Volume control along with the VMC Control.

Diagram #2
Master Volume
VMC Control

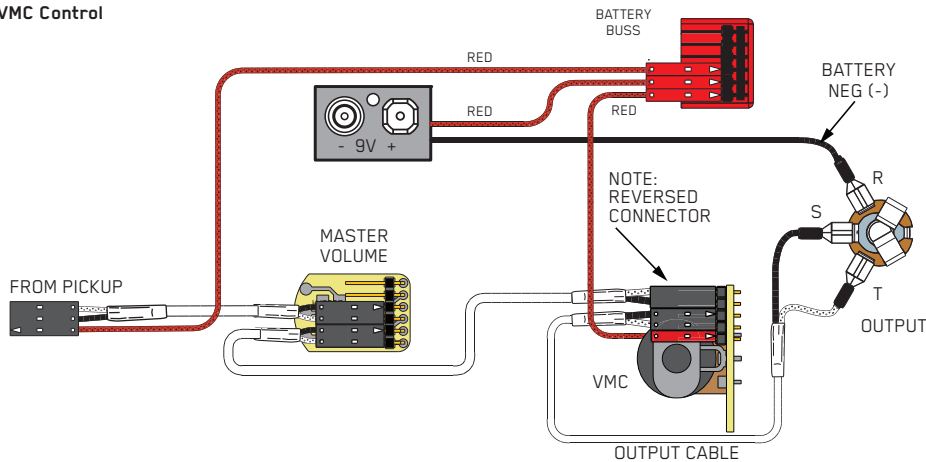
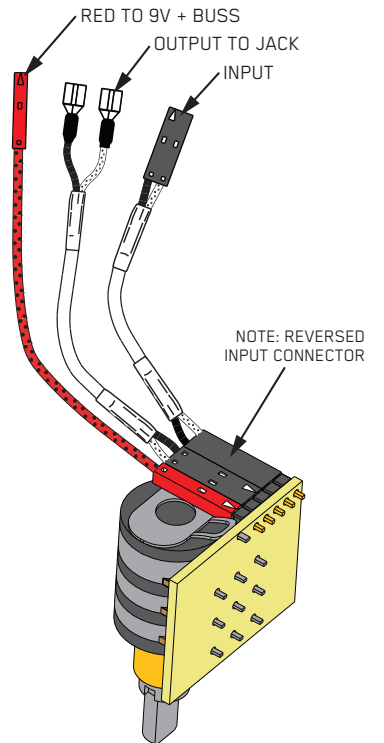

Diagram #1



**Installation Instructions:
EMG Model: VMC Control**

2 Pickups, 2 Volume controls, VMC Control, no selection switch

J-Bass Style wiring

Refer to Diagram #3

- 1) Install the Pickups and route the Pickup cables to the control cavity.
If the cables are too long, keep any excess under the pickup.
- 2) Mount the Volume and Tone controls into the body / pickguard.
Plug the Neck Pickup Cable onto the Neck Volume control.
Plug the Bridge Pickup Cable onto the Bridge Volume control.
- 3) Plug a coax cable from the Neck Volume control to the Bridge Volume control.
- 4) Plug a coax cable from the Bridge Volume control to the VMC Control.

- 5) Plug the output cable from the VMC Control and connect the output wires to the output jack by pushing the connectors on as shown.
WHITE wire onto the TIP (T) contact,
BLACK wire onto the SLEEVE (S) contact
BLACK Battery Negative wire onto the RING (R) contact.
- 6) Plug the RED Wires of the pickups onto the V+ Supply Buss (RED Shroud) along with the RED of the battery clip.
Extra pins on the V+ Supply Buss are for EMG Accessories.
- 7) Put the battery in the insulating foam piece provided and place it securely in the control cavity.

We suggest that you plug in the instrument and test it before closing the control cavity.

**Diagram #3
Volume / Volume
VMC Control**

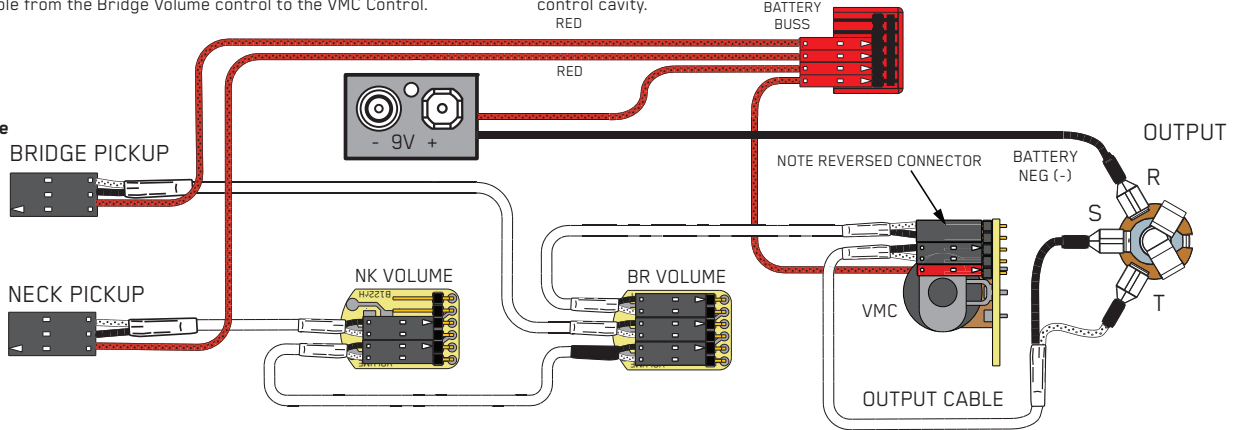

Installation (Two Pickup Guitars with Selection switch):

Guitars with two pickups and a selection switch will use the EMG B245 Pickup Buss shown at the right in Diagram #4a.

The Pickup Buss is a convenient way to wire your guitar without soldering. There is a separate sheet attached to these instructions that describes the Pickup Buss in detail.

In all installations it's best to find a place to mount the Pickup Buss in the control cavity before starting. Then, after the cables are routed use the velcro to mount it securely.

2 Pickups / Toggle Select Switch / Master Volume and VMC Control

- 1) Install the Pickups and route the Pickup cables to the control cavity.
If the cables are too long, wind up the excess and keep it under the pickup.
- 2) Mount the Volume and Tone controls into the body.
Plug both Pickup cables into the Pickup Buss (BLACK Shroud) as shown, Refer to Diagram #4a
Bridge Pickup to Position 1
Neck Pickup to Position 2.
- 3) Plug a coax cable from the Pickup Buss (Position 3) to the Master Tone (Active) as shown in Diagram #4b. Note the reversed connector on pins 1 and 2.
- 4) Plug a coax cable from the Master Tone (ACTIVE) to the Master Volume as shown.
- 5) Strip the insulation from the switch wires and Insert them into the GREEN Terminal Block and tighten the screws with a small screwdriver.
The Bridge pickup goes to the BR Terminal
The Neck pickup goes to the NK Terminal
The Output of the switch goes to the O Terminal
If there is a ground wire coming from the switch, insert it into one of the black terminals on the terminal block.

Diagram #4a

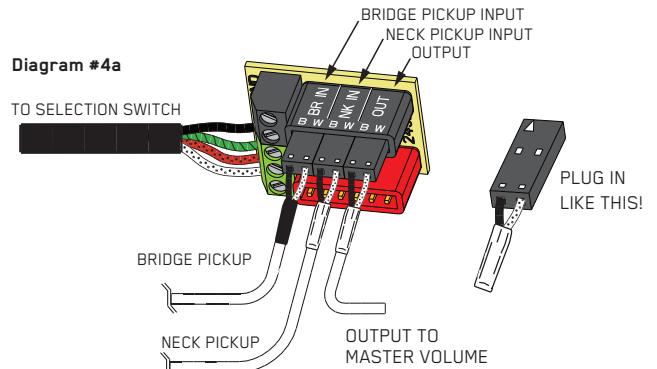

- 6) Plug the output cable onto the Master Volume control and connect the output wires to the output jack and push the connectors onto the jack as shown.
WHITE wire onto the TIP (T) contact,
BLACK wire onto the SLEEVE (S) contact
BLACK Battery Negative wire onto the RING (R) contact.
- 7) Plug the RED Wires of the pickups onto the V+ Supply Buss (RED Shroud) along with the RED of the battery clip, and the RED wire of the Active Tone Control. Extra pins on the V+ Supply Buss are for EMG Accessories.
- 8) Put the battery in the insulating foam piece provided and place it securely in the control cavity.
We suggest that you plug in the instrument and test it before closing the control cavity.

**Diagram #4b
2 Pickups
Toggle Style Select Switch
Master Volume & Master Tone**

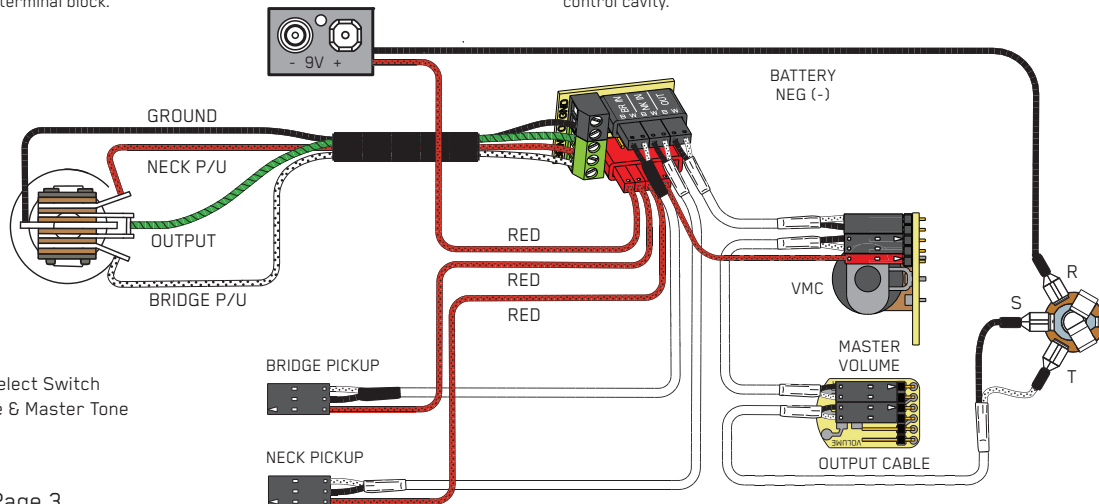

Diagram #5
ABC Balance Control
Master Volume
VMC Control
Output Jack

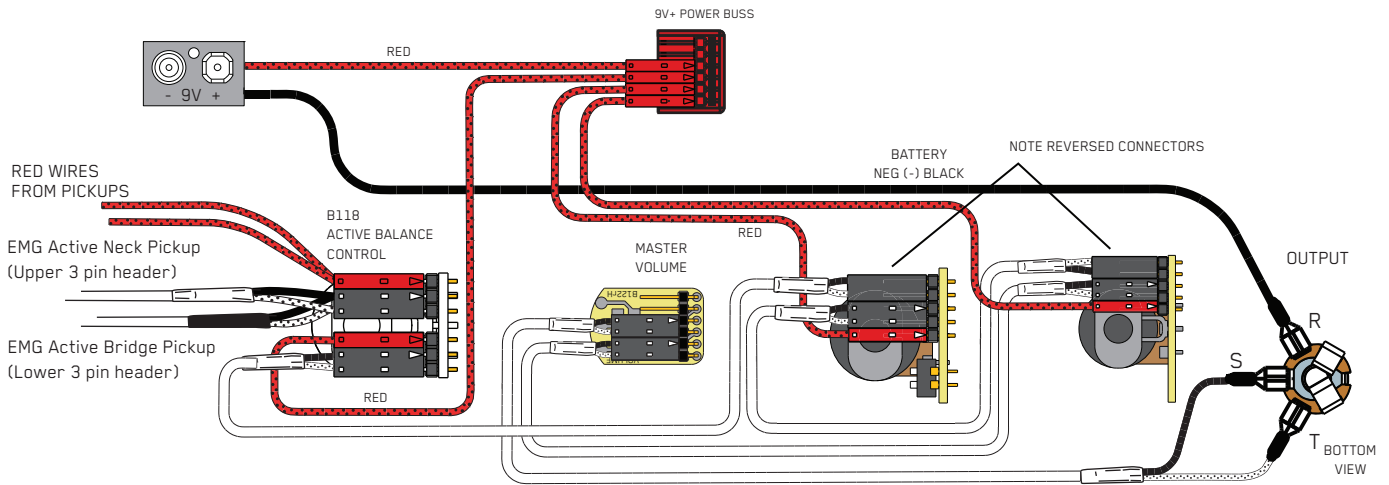
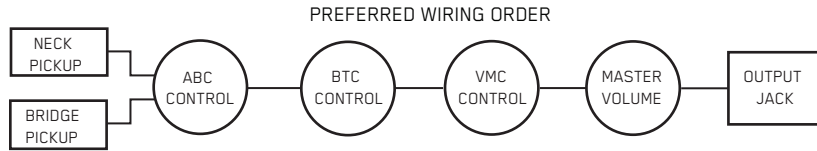

Diagram #6

If the instrument has a Battery Holder:

If your instrument has a 9 or 18-Volt battery holder you can still use the EMG Connectors to supply power to the pickups. Simply cut and strip the wires from the battery clip provided. Twist the wires together (Red to Red and Black to Black) and use the shrink tubing included to cover the connections. Soldering the wires is recommended.

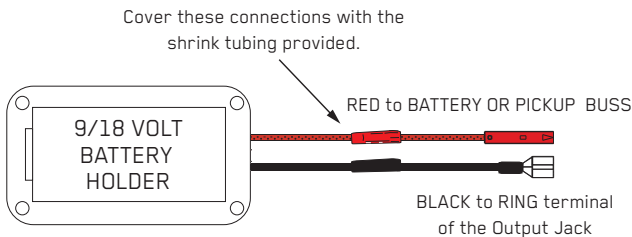

Diagram #7

+18 Volt Wiring Option:

If you want to operate your instrument at +18 Volts for more headroom then use 2 batteries wired as below. Also, if you are using any type of EQ in your instrument (EMG-BT, BQ) or anything that boosts the pickup signal then +18 Volts is recommended.

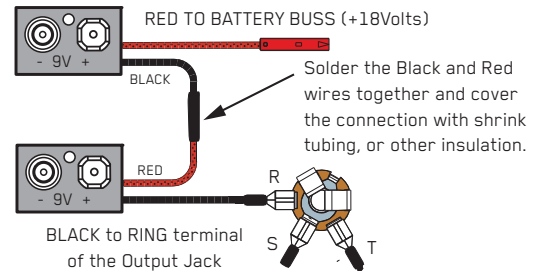

Diagram #8

Soldering to the 152B Panel Jack:

If your instrument has a long Panel Jack like the one below you will have to solder the output cable as shown. Ground (Black) to the Sleeve
 Signal (White) to the Tip
 Battery Negative (Black) to the Ring

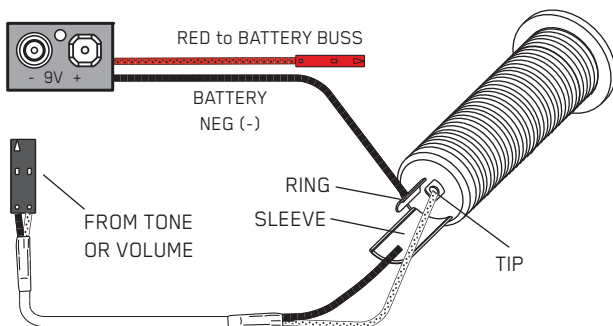

Diagram #9

Soldering to the battery buss:

If your instrument has an older EMG Pickup you can solder the pickup RED wire to the buss. Simply use some needle nose pliers, pull out the V+ header and solder the RED Wire from the pickup(s) to any of the pins and then re-insert the header into the housing.

