

EMG

P.O. BOX 4394
SANTA ROSA, CA
95402 U.S.A.
PH (707) 525-9941
FX (707) 575-7046
www.emgpickups.com

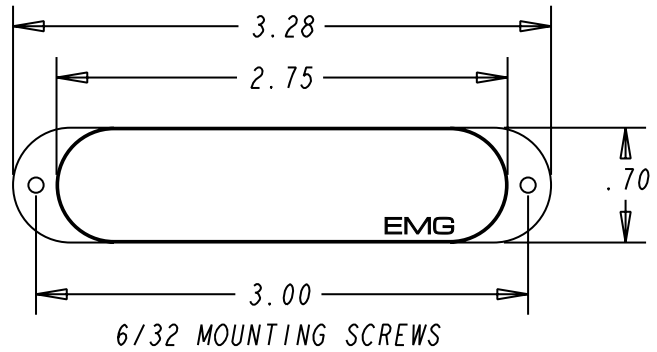
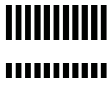

INSTALLATION INFORMATION

EMG Model: EMG-DG-20
(EMG-SA System with EMG-EXG / SPC)

SPECIFICATIONS:

MODEL:

SA System w/ EXG and SPC

Logo Color	Gold
Magnet type	Alnico
Resonant Frequency (KHz)	4.45
Output Voltage (String)	1.0
Output Voltage (Strum)	1.50
Output Noise@ 60Hz	-91
Output Impedance (Kohm)	10
Current@ 9V (Microamps)	1240
Battery Life (Hours)	500
Maximum Supply (Volts DC)	27

IMPORTANT INSTALLATION NOTES:

- 1) Only one battery is required for the pickups, and any active accessories such as the SPC, RPC, EXG, AB, PA-2, and Pi-2.
- 2) Use an Alkaline or Lithium battery for longest life.
- 3) The controls included with EMG Systems are 25K Ohm, Audio Taper. This value of control is required for the system to work correctly.
- 4) When installing EMG Active Pickups, DO NOT connect the bridge ground wire. This wire is usually soldered to a volume or tone control casing and goes to the bridge. This wire grounds the strings and uses them and your body as a shield against hum and buzz. It also creates a shock hazard. EMG Pickups are shielded internally and DO NOT require string grounding. This greatly reduces the possibility of reverse polarity shock from microphones and other equipment
- 5) EMG Active Pickups have very little magnetism compared to passive pickups. We recommend you adjust the pickups as close to the strings as possible. Sustain and string movement will not be inhibited by close adjustment.
- 6) If your installation is different from the diagrams in these instructions or you need additional diagrams visit our website: emgpickups.com for a complete listing of available diagrams.



P.O. BOX 4394
SANTA ROSA, CA
95402 U.S.A.
PH (707) 525-9941
FX (707) 575-7046
www.emgpickups.com

Warranty:

All EMG Pickups and accessories are warranted for a period of two years. This warranty does not cover failure due to improper installation, abuse or damage. If upon examination the pickup is determined to be defective, a replacement will be made at no charge. Warranty replacement products are covered by this same warranty. This warranty covers only those pickups and accessories sold by authorized EMG Dealers. This warranty is not transferable.

Installation Procedures for EMG Model DG-20

- 1) Remove the strings.
- 2) Unscrew the output jack plate and unsolder the wires from the output jack.
- 3) Unscrew and remove the pickguard from the body with the pickups, controls and selection switch intact.
- 4) Cut the bridge ground wire going to the vibrato cavity. It will not be reconnected. See: IMPORTANT NOTES (note 4) on page 1.
- 5) Replace the existing jack with the EMG output jack. With the jack mounted in the jackplate, test the fit of the jackplate in the jack cavity with a plug inserted. Make sure the plug slides in and out easily without binding. If the fit isn't good, rotate the jack on the jack plate so the plug will go in and out easily.
- 6) Route the Green and one of the Black wires from the EMG quick connect and the black wire of the battery clip from the control cavity into the jack cavity. Put, (but do not fasten yet), the DG20 pickguard in place.
- 7) Solder the output wire (Green), Black from the connector and the battery black wire to the output jack as shown on diagram 2.
- 8) Connect a battery to the battery clip. Wrap the battery in some foam or tape. Place it beneath the volume control, next to the 5-way switch.
- 9) Before fastening the pickguard and jackplate to the body, use a screwdriver and tap lightly on each pickup while plugged into an amp. If everything is working correctly, screw down the pickguard and jackplate and restring the guitar.

Be sure to unplug your guitar when not in use to avoid current drain on the battery!

