



0230-0134A

PO BOX 4394
SANTA ROSA, CA
95402 USA

P (707) 525-9941
F (707) 575-7046
EMGPICKUPS.COM

INSTALLATION INFORMATION EMG MODEL: 808 PICKUP (8-STRING)

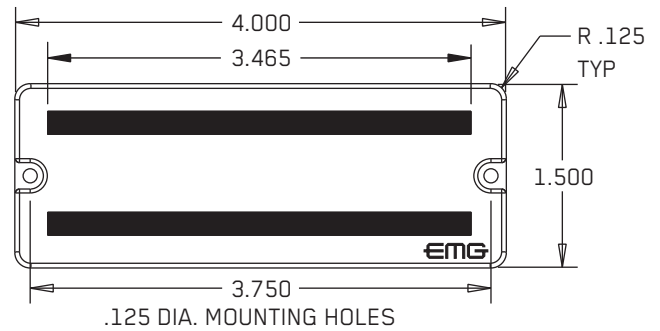

MAXIMUM RECOMMENDED STRING WIDTH 3.00"

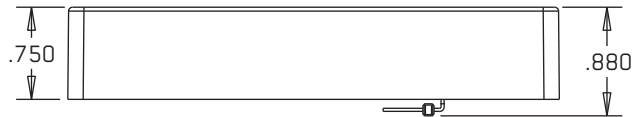

SPECIFICATIONS:

Logo Color
Magnet Type
Resonant Frequency (KHz)
Output Voltage (String)
Output Voltage (Strum)
Output Noise (60 Hz)
Output Impedance (Kohm)
Current @9V (Microamps)
Battery Life (Hours)
Maximum Supply (Volts DC)

MODEL:

808
Gold
Alnico
1.90
2.00
4.50
-104
10
80
3000
27

INSTALLATION NOTES:

All EMG Pickups are compatible with each other. The connector system is an easy method of installation, avoiding the need to solder. Older systems may need to be soldered, while the newer systems can be easily connected and modified. If you have an older EMG Pickup you can install the new system along with it. EMG accessories like the VLPF, EXG, SPC or RPC Controls can be added to any EMG Pickup System without the need for an extra battery.

IMPORTANT INSTALLATION NOTES:

- 1) Only one 9-Volt battery is required to power the pickups and any accessories such as the EXB, BTC, B125 Blend, and BQ Controls. Use an Alkaline or Lithium battery for longest life.
- 2) The Volume and Tone controls included with this EMG System are 25K Ohm. This value is required for the system to work correctly.
- 3) A stereo output jack (12B) is included with the EMG Pickups; it grounds the black battery wire to turn on the pickups when the plug is inserted into the jack. If you are replacing passive pickups, make sure to use the jack included. If your guitar has a long panel jack make sure it is a stereo type, a Switchcraft 152B is recommended.
- 4) When installing EMG Active Pickups, DO NOT connect the bridge ground wire. This wire is usually soldered to a volume or tone control casing and goes to the bridge. This wire grounds the strings and uses them and your body as a shield against hum and buzz. It also creates a shock hazard.

EMG Pickups are shielded internally and DO NOT require string grounding. This greatly reduces the possibility of reverse polarity shock from microphones and other equipment.

- 5) EMG Active Pickups have very little magnetism compared to passive pickups. We recommend you adjust the pickups as close to the strings as possible. Sustain and string movement will not be inhibited by close adjustment.
- 6) If your installation is different from the diagrams in these instructions or you need additional diagrams visit our website: emgpickups.com for a complete listing of available diagrams.

7) SPECIAL NOTE:

The diagrams shown are for EMG Active Pickups. All diagrams show the Red Wire coming from the pickups connected to the battery. If you are installing EMG-HZ Passive Pickups refer to their diagrams. The Red Wire of the HZ Pickup is NOT for battery power, it is a coil wire.

WARRANTY

All EMG Pickups and accessories are warranted for a period of two years. This warranty does not cover failure due to improper installation, abuse or damage. If upon examination the pickup is determined to be defective, a replacement will be made. Warranty replacement products are covered by this same warranty. This warranty covers only those pickups and accessories sold by authorized EMG Dealers. This warranty is not transferable.

Installation Instructions:

EMG Model: 808 PICKUP (8-STRING)

General Notes:

Every attempt has been made to make this a solderless installation.

There are some instances where this is not possible;

- 1) If your instrument uses the long panel output jack and you had passive pickups you will need a new stereo output jack, the Switchcraft 152B is recommended. Soldering to the new jack will be required, see Diagram #4 below.
- 2) Some instruments may already have a battery holder installed and in that case soldering may be required to the battery buss, see diagram #5 below.
- 3) Instruments with two pickups may need soldering to the selection switch in some installations.

If you are installing only one pickup use the instructions on this page.

If you are installing two pickups go to page 3 and begin there.

Installation (One Pickup Guitars):

- 1) Plug the pickup cable onto the EMG Pickup header as shown in Diagram #1 and route the cable to the control cavity. If the cable is too long, wind up the excess and keep it under the pickup if possible.

Master Volume control only

2) Refer to Diagram #2.

Plug both the Pickup cable and the output cable onto the Volume control as shown, then go to step 4.

Master Volume and Tone control

3) Refer to Diagram #3.

Plug the Pickup cable onto the Volume control as shown. Plug a coax cable from the Volume control to the Tone control. Plug the output cable onto the Tone control as shown.

- 4) Connect the wires of the output cable to the output jack by pushing the connectors on as shown.

WHITE wire to the TIP (T) contact,
BLACK wire to the SLEEVE (S) contact
BLACK Battery Negative wire to the RING (R) contact.

- 5) Using the battery buss, insert the RED wire of the pickup, and the battery RED wire. Extra pins can be used for EMG Accessories.

- 6) Put the battery in the insulating foam piece provided and place it securely in the control cavity. We suggest that you plug in the instrument and test it before closing the control cavity.

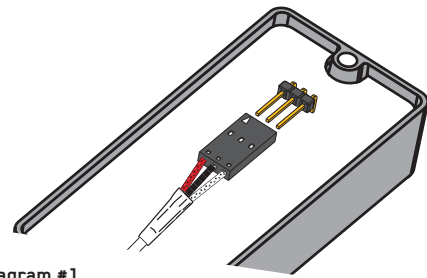

Diagram #1

Insert the plug onto the 3 pin header of the pickup as shown above. Note the orientation arrow.

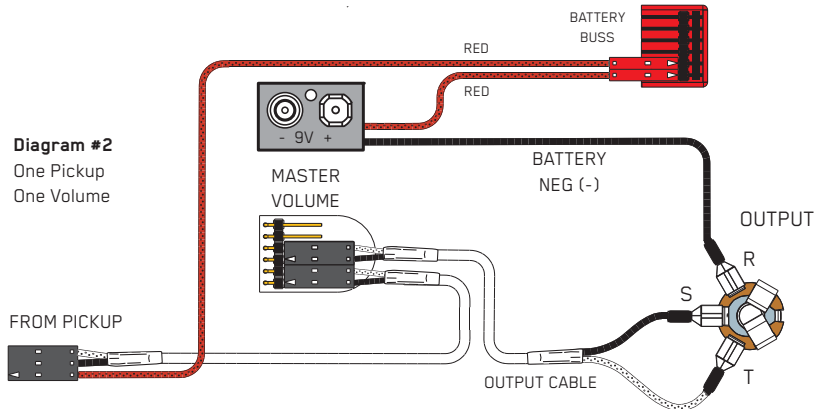

Diagram #2

One Pickup
One Volume

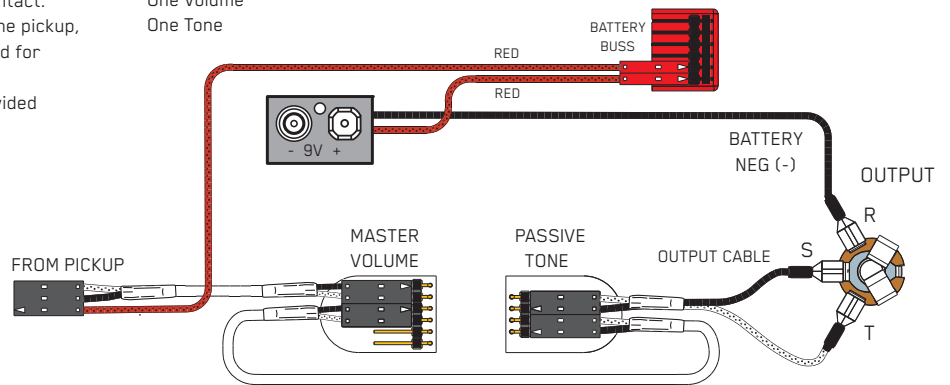

Diagram #3

One Pickup
One Volume
One Tone

Diagram #4

Soldering to the 152B Panel Jack:

If your instrument has a long Panel Jack like the one below you will have to solder the output cable as shown.
Ground (Black) to the sleeve
Signal (White) to the Tip
Battery Negative (Black) to the Ring

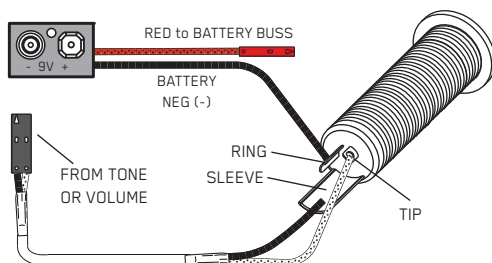
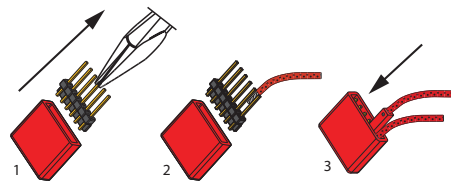

Diagram #5

Soldering to the battery buss:

If your instrument has an older EMG Pickup you can solder the pickup RED wire to the buss. Simply use some needle nose pliers, pull out the V+ header and solder the RED Wire from the pickup(s) to any of the pins and then re-insert the header into the housing.



Solder the RED wire from the Battery Holder and/or pickups and re-insert the Header into the insulation cover

Installation Instructions:

EMG Model: 808 PICKUP

Installation (Two Pickup Guitars with Selection switch):

Guitars with two pickups and a selection switch will use the EMG B157 Pickup Buss. The Pickup Buss is a convenient way to wire your guitar without soldering. There is a separate sheet attached to these instructions that describes the Pickup Buss in detail.

In all installations it's best to find a place to mount the Pickup Buss in the control cavity before starting. Then, after the cables are routed use the velcro to mount it securely.

2 Pickups / Toggle Select Switch / Master Volume and Tone

- 1) Install the Pickups and route the Pickup cables to the control cavity.
If the cables are too long, wind up the excess and keep it under the pickup.
- 2) Mount the Volume and Tone controls into the body.
Plug both Pickup cables onto the Pickup Buss (BLACK Shroud) as shown,
Refer to Diagram #6a
Bridge Pickup to Position 1
Neck Pickup to Position 2.
- 3) Plug a coax cable from the Pickup Buss (Position 3) to the Master Volume control as shown in diagram #6b.
- 4) Plug a coax cable from the Master Volume to the Master Tone as shown.
- 5) Strip the insulation from the switch wires and Insert them into the GREEN Terminal Block and tighten the screws with a small screwdriver.
The Bridge pickup goes to the BR Terminal
The Neck pickup goes to the NK Terminal
The Output of the switch goes to the O Terminal
If there is a ground wire coming from the switch, insert it into one of the black terminals on the terminal block.
- 6) Plug the output cable onto the Master Tone control and connect the output wires to the output jack by pushing the connectors on as shown.
WHITE wire onto the TIP (T) contact,
BLACK wire onto the SLEEVE (S) contact
BLACK Battery Negative wire onto the RING (R) contact.

Diagram #6b

2 Pickups
Toggle Style Select Switch
Master Volume & Master Tone

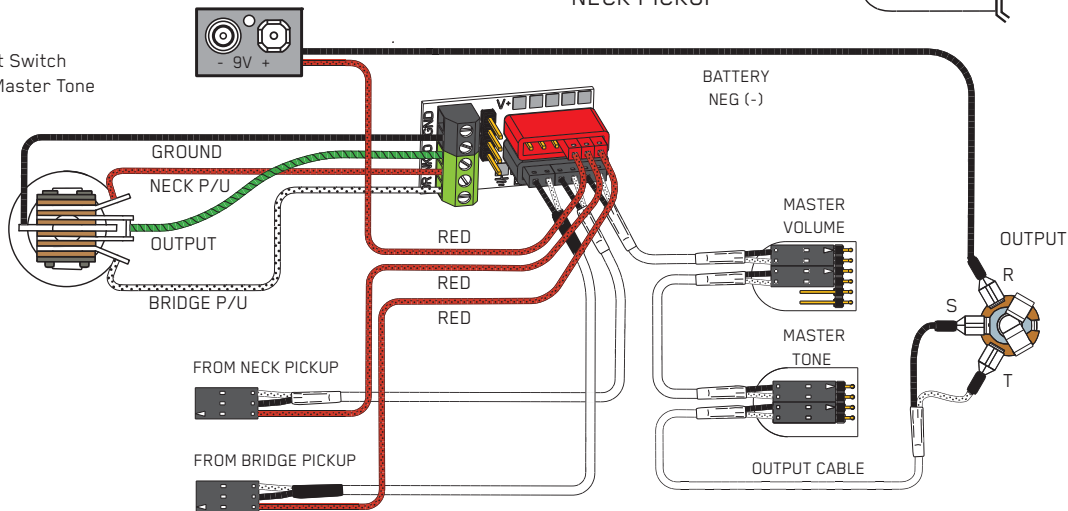

****Tips and Tricks****

Start your installation by:

- 1) Read the General Notes on Page 2 if you haven't already and determine if you have the right output jack for your instrument. A Stereo 12B type (Included) or a 152B Long Panel Jack will be required.
- 2) Remove the strings
- 3) Remove any existing Pickups and controls (remember the order and function of each control)
- 4) Determine a good spot for the Pickup Buss and make sure the cable or wires from the selection switch will reach the Pickup Buss,
- 5) Install the EMG Volume and Tone Controls and tighten them in.
- 6) Then install the pickups keeping any excess cable under the pickup rather than in the control cavity.

- 7) Plug the RED Wires of the pickups onto the V+ Supply Buss (RED Shroud) along with the RED of the battery clip.
Extra pins on the V+ Supply Buss are for EMG Accessories.
- 8) Put the battery in the insulating foam piece provided and place it securely in the control cavity.
We suggest that you plug in the instrument and test it before closing the control cavity.

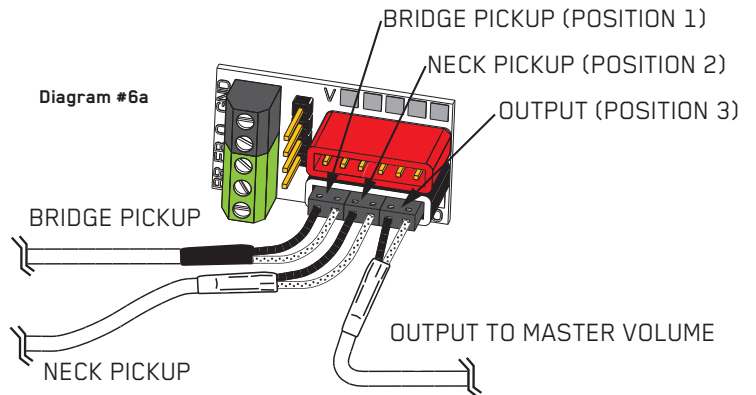

2 Pickups / Toggle Select Switch / 2 Volumes and Master Tone

Refer to Diagram #7 (Next Page)

- 1) Install the Pickups and route the Pickup cables to the control cavity.
If the cables are too long, wind up the excess and keep it under the pickup.
- 2) Mount the Volume and Tone controls into the body.
Plug both pickup cables onto the Volume controls as shown.
Plug a coax cable from the Bridge Volume control to the Pickup Buss (Position 1)
Plug a coax cable from the Neck Volume control to the Pickup Buss (Position 2)
- 3) Plug a coax cable from the Pickup Buss (Position 3) to the Master Tone control as shown.
- 4) Strip the insulation from the switch wires and Insert them into the GREEN Terminal Block and tighten the screws with a small screwdriver.
The Bridge pickup goes to the BR Terminal
The Neck Pickup goes to the NK Terminal
The Output of the switch goes to the O Terminal
If there is a ground wire coming from the switch, insert it into one of the black terminals on the terminal block.
- 5) Plug the output cable onto the Tone control and connect the wires to the output jack by pushing the connectors on as shown.
WHITE wire onto the TIP (T) contact,
BLACK wire onto the SLEEVE (S) contact
BLACK Battery Negative wire onto the RING (R) contact.
- 6) Plug the RED Wires of the pickups onto the V+ Supply Buss (RED Shroud) along with the RED of the battery clip. Extra pins are for EMG Accessories.
- 7) Put the battery in the insulating foam provided and place it securely in the control cavity.
We suggest that you plug in the instrument and test it before closing the control cavity.

Diagram #7

2 Pickups
 Toggle Style Switch
 Volume each Pickup (Volumes are independent)
 Master Tone

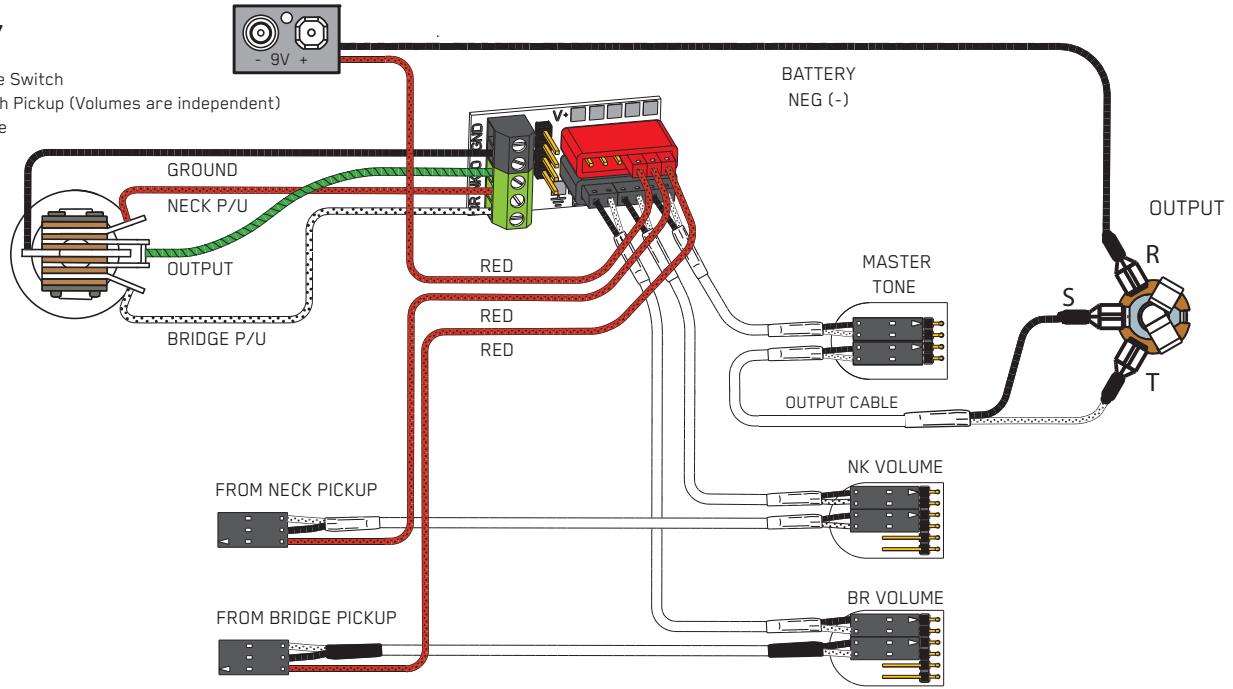

2 Pickups / Toggle Select Switch / 2 Volumes and 2 Tones)
 Refer to Diagram #8

- 1) Install the Pickups and route the cables to the control cavity.
 If the cables are too long, wind up the excess and keep it under the pickup.
 - 2) Mount the Volume and Tone controls into the body
 Plug both Neck and Bridge pickup cables onto the Volume Controls as shown.
 Plug a coax cable from the Bridge (BR) Volume control to the Pickup Buss (Position 1).
 Plug a coax cable from the Neck (NK) Volume control to the Pickup Buss (Position 2).
 - 3) Plug a coax cable from the Bridge (BR) Volume control to the Bridge (BR) Tone control as shown.
 - 4) Plug a coax cable from the Neck (NK) Volume control to the Neck (NK) Tone control as shown.
 - 5) Strip the insulation from the switch wires and Insert them into the GREEN Terminal Block and tighten the screws with a small screwdriver.
 The Bridge pickup goes to the BR Terminal
 The Neck Pickup goes to the NK Terminal
 The Output of the switch goes to the O Terminal
 If there is a ground wire coming from the switch, insert it into one of the black terminals on the terminal block.
 - 6) Plug the output cable onto the Pickup Buss (Position 3) and push the connectors onto the jack as shown.
 WHITE wire onto the TIP (T) contact,
 BLACK wire onto the SLEEVE (S) contact
 BLACK Battery Negative wire onto the RING (R) contact.
 - 7) Plug the RED Wires of the pickups onto the V+ Supply Buss (RED Shroud) along with the RED of the battery clip. Extra pins are for EMG Accessories.
 - 8) Put the battery in the foam insulator provided and place it securely in the control cavity.
- We suggest that you plug in the instrument and test it before closing the control cavity.

Diagram #8

2 Pickups
 2 Volume (either volume will act as a master)
 2 Tone
 Toggle Style Switch

